

# HITACHI

2018 FİYAT LİSTESİ

**KALE**!!!

Gücün Kalesi, Kale'nin Gücü!





- Akülüler

1



- Matkaplar
- Karıştırıcılar
- Elektrikli tornavidalar
- Darbeli somun sıkımlar

2



- Avuç taşlamalar
- Büyük taşlamalar
- Polisaj
- Kalıpçı taşlamalar

3



- Deliciler
- Kırıcı deliciler
- Kırıcılar
- Beton kesme

4



- Daire testereler
- Profil kesme
- Gönye kesme
- Raylı gönye kesmeler

5



- Planyalar
- Eksantrik zımpara
- Titreşimli zımparalar
- Tank zımparalar
- Frezeler

6



- Dekupajlar
- Sac kesme
- Tilki kuyruğu
- Üfleyiciler, Sıcak hava tabancaları
- Yüksek basınçlı yıkamalar
- Elektrikli zincir testere

7



- Aksesuarlar

8

## HITACHI ELEKTRİKLİ EL ALETLERİ

MODELİ	CİNSİ	ÖZELLİĞİ	FİYATI	SYF. NO
AW 100	Yüksek Basınçlı Yıkama	100 bar / 1400 W	155-\$	66
AW 130	Yüksek Basınçlı Yıkama	130 bar / 1600 W	245-\$	66
AW 150	Yüksek Basınçlı Yıkama	150 bar / 2000 W	450-\$	66
AW 18DBL	Akülü Basınçlı Yıkama	20 bar / 18 V / 5.0 Ah	890-\$	18
C 10FCE2	Gönye Kesme	255 mm / 1520 W	370-\$	53
C 12RSH2	Raylı Gönye Kesme - Lazerli Kes. Çiz.	305 mm / 1520 W	850-\$	54
C 7MFA	Daire Testere	190 mm / 1010 W	130-\$	52
C 8FSE	Raylı Gönye Kesme	216 mm / 1050 W	555-\$	54
C 9U3	Daire Testere	235 mm / 2000 W	260-\$	52
CC 14ST	Profil Kesme - Karbon Taşlı	355 mm / 2200 W	230-\$	53
CE 16SA	Sac Kesme	1.6 mm / 400 W	490-\$	63
CJ 110MV	Dekupaj	110 mm / 720 W	220-\$	62
CJ 14DSL	Akülü Dekupaj	135 mm / 14.4 V / 3.0 Ah	535-\$	19
CJ 160V	Dekupaj	60 mm / 800 W	250-\$	63
CJ 160VA	Dekupaj	60 mm / 800 W	250-\$	63
CJ 65V3	Dekupaj	65 mm / 400 W	110-\$	62
CJ 90VST	Dekupaj	90 mm / 705 W	150-\$	62
CM 12Y	Beton Kesme	100 mm / 2400 W	1,350-\$	50
CR 10DL	Akülü Tilki Kuyruğu	10.8 V / 1.5 Ah / 25 mm	270-\$	19
CR 13V2	Tilki Kuyruğu	300 mm / 1010 W	230-\$	64
CR 18DSL	Akülü Tilki Kuyruğu	18 V / 3.0 Ah / 90 mm	550-\$	19
CS 40SB	Elektrikli Zincirli Testere	400 mm / 1900 W	170-\$	65
D 10VC3	Darbesiz Matkap	10 mm / 600 W	72-\$	22
D 10YB	Köşe Matkap	10 mm / 500 W	410-\$	22
D 13VL	Darbesiz Matkap	13mm / 860 W	220-\$	22
DB 3DL2	Akülü Vidalama	3.6 V / 1.5 Ah / 5 Nm	135-\$	15
DH 18DBL	Akülü Kırıcı Delici	26 mm / 18 V / 5.0 Ah	690-\$	18
DH 24PH	Kırıcı Delici	24 mm / 730 W	180-\$	44
DH 26PB	Delici	26 mm / 830 W	175-\$	44
DH 26PC	Kırıcı Delici	26 mm / 830 W	195-\$	44
DH 28PCY	Kırıcı Delici	28 mm / 850 W	250-\$	45
DH 36DBL	Akülü Kırıcı Delici	28 mm / 36 V / 2.6 Ah	1,150-\$	18
DH 40MC	Kırıcı Delici	40 mm / 1000 W	530-\$	45
DH 45ME	Kırıcı Delici	45 mm / 1500 W	900-\$	47
DH 52ME	Kırıcı Delici	52 mm / 1500W	1,020-\$	47
DS 10DAL	Akülü Matkap Vidalama	10.8 V / 1.5 Ah / 36 Nm	185-\$	10
DS 14DBSL	Akülü Matkap Vidalama	14.4 V / 5.0 Ah / 60 Nm	395-\$	10
DS 14DFL	Akülü Matkap Vidalama	14.4 V / 1.5 Ah / 47 Nm	210-\$	10
DS 14DSDL	Akülü Matkap Vidalama	14.4 V / 5.0 Ah / 82 Nm	365-\$	10
DS 18DBSL	Akülü Matkap Vidalama	18V / 5.0 Ah / 75 Nm	420-\$	12
DS 18DFL	Akülü Matkap Vidalama	18V / 1.5 Ah / 53 Nm	290-\$	11
DS 18DJL	Akülü Matkap Vidalama	18V / 1.5 Ah / 55 Nm	290-\$	11
DS 18DSDL	Akülü Matkap Vidalama	18V / 5.0 Ah / 92 Nm	380-\$	12
DV 14DSDL	Akülü Darbeli Matkap Vidalama	14.4 V / 5.0 Ah / 82 Nm	380-\$	13
DV 16VSS	Darbeli Matkap	13 mm / 600 W	88-\$	23
DV 18DBSL	Akülü Darbeli Matkap Vidalama	18 V / 5.0 Ah / 70 Nm	440-\$	14
DV 18DJL	Akülü Darbeli Matkap Vidalama	18 V / 1.5 Ah / 55 Nm	310-\$	13
DV 18DSDL	Akülü Darbeli Matkap Vidalama	18 V / 5.0 Ah / 92 Nm	405-\$	14
DV 18V	Darbeli Matkap	13 mm / 690 W	145-\$	24
DV 20VD	Darbeli Matkap	13 mm / 860 W	255-\$	24
DV 22V	Darbeli Matkap	13 mm / 1120 W	275-\$	24
FDV 16VB2	Darbeli Matkap	13 mm / 550 W	78-\$	23
FSV 10SA	Titreşimli Zımpara	94x184 mm / 180 W	90-\$	58
G 12SE2	Avuç Taşlama	115 mm / 1200 W	165-\$	36

## HITACHI ELEKTRİKLİ EL ALETLERİ

MODELİ	CİNSİ	ÖZELLİĞİ	FİYATI	SYF. NO
G 12SN	Avuç Taşlama	115 mm / 840 W	93-\$	35
G 12SQ	Avuç Taşlama	115 mm / 840 W	105-\$	36
G 12SR4	Avuç Taşlama	115 mm / 730 W	75-\$	35
G 12STA	Avuç Taşlama	115 mm / 600 W	59-\$	35
G 12SW	Avuç Taşlama	115 mm / 1200 W	135-\$	36
G 13SB3	Avuç Taşlama	125 mm / 1300 W	160-\$	37
G 13SN	Avuç Taşlama	125 mm / 840 W	93-\$	37
G 13VA	Elektronik Avuç Taşlama	125 mm / 1500 W	265-\$	38
G 14DSL	Akülü Avuç Taşlama	115 mm / 14.4 V / 3.0 Ah	450-\$	20
G 18DBL	Akülü Avuç Taşlama	115 mm / 18 V / 5.0 Ah	575-\$	20
G 18DSL	Akülü Avuç Taşlama	115 mm / 18 V / 3.0 Ah	505-\$	20
G 18MR	Büyük Taşlama	180 mm / 2400 W	220-\$	38
G 18ST	Büyük Taşlama	180 mm / 2200 W	140-\$	38
G 23SE2	Büyük Taşlama	230 mm / 2500 W	245-\$	39
G 23ST	Büyük Taşlama	230 mm / 2200 W	150-\$	39
GP 2S2	Kalıpçı Taşlama	6 mm / 520 W	255-\$	40
GP 3V	Kalıpçı Taşlama, Devir Ayarlı	6 mm / 760 W	320-\$	40
H 41MB	Kırıcı	5 kg / 930 W	550-\$	48
H 45ME	Kırıcı	7 kg / 1150 W	830-\$	48
H 60MC	Kırıcı	10 kg / 1250 W	720-\$	48
H 60ME	Kırıcı	11 kg / 1500 W	890-\$	49
H 65SB3	Kırıcı	18 kg / 1340 W	1,260-\$	49
H 70SA	Kırıcı	20 kg / 1240 W	1,400-\$	50
H 90SG	Kırıcı	32 kg / 2000 W	1,950-\$	50
M 12VE	Freze	12 mm / 2000 W	385-\$	60
M 8V2	Freze	8 mm / 1150 W	370-\$	60
P 20SA2	Planya	82 mm / 720 W	380-\$	56
P 20ST	Planya	82 mm / 580 W	126-\$	56
RB 40SA	Üfleyici	3.8 m3/dk. / 550 W	140-\$	64
RB 40VA	Üfleyici - Devir Ayarlı	3.8 m3/dk. / 550 W	145-\$	64
RH 600T	Sıcak Hava Tabancası	600 °C / 2000 W	60-\$	65
RH 650V	Sıcak Hava Tabancası - Isı Ayarlı	650 °C / 2000 W	89-\$	65
SB 10S2	Tank Zımpara	100x 610 mm / 1020 W	300-\$	57
SB 10V2	Tank Zımpara - Devir Ayarlı	100x 610 mm / 1020 W	325-\$	57
SP 18VA	Polisaj	180 mm / 1250 W	265-\$	39
SV 12SD	Titreşimli Zımpara	114x228 mm / 300 W	215-\$	59
SV 12SG	Titreşimli Zımpara	110x100 mm / 200 W	95-\$	58
SV 12SH	Titreşimli Zımpara	110x190 mm / 200 W	116-\$	58
SV 13YA	Eksantrik Zımpara	125 mm / 230 W	165-\$	59
UM 12VST	Karıştırıcı	120 mm / 1100 W	215-\$	26
UM 16VST	Karıştırıcı	160 mm / 1500 W	240-\$	26
VTV 16	Darbeli Matkap	16 mm / 800 W	490-\$	25
W 6V4	Elektrikli Tornavida	620 W / 4500 dev/dak	195-\$	27
W 6VA4	Elektrikli Tornavida	620 W / 3000 dev/dak	185-\$	27
W 6VM	Elektrikli Tornavida	620 W / 6000 dev/dak	205-\$	27
WH 10DAL	Akülü Darbeli Vidalama	10.8 V / 1.5 Ah / 108 Nm	250-\$	10
WH 10DCL	Akülü Darbeli Köşe Matkap	10.8 V / 1.5 Ah / 30 Nm	320-\$	15
WH18DBDL2	Akülü Darbeli Vidalama	18 V / 5.0 Ah / 207 Nm	555-\$	16
WR 14DBDL2	Akülü Darbeli Somun Sıkma	14.4 V / 5.0 Ah / 285 Nm	580-\$	17
WR 14VE	Darbeli Somun Sıkma	250 Nm / 370 W	490-\$	29
WR 16SE	Darbeli Somun Sıkma	360 Nm / 370 W	520-\$	29
WR 18DBDL2	Akülü Darbeli Somun Sıkma	18 V / 5.0 Ah / 305 Nm	630-\$	17
WR 18DSHL	Akülü Darbeli Somun Sıkma	18 V / 3.0 Ah / 480 Nm	825-\$	17
WR 22SE	Darbeli Somun Sıkma	610 Nm / 850 W	740-\$	32
WR 25SE	Darbeli Somun Sıkma	1000 Nm / 900 W	1,030-\$	32

## KULLANIM İLE İLGİLİ UYARI ve ÖNLEMLER

### DİKKAT!

**Elektrikli el aletleri kullanılırken, elektrik çarpması, yaralanma ve yangına karşı korunmak üzere aşağıdaki temel güvenlik önlemlerine uyulmalıdır.**

#### Güvenli bir kullanım için:

- 1- Kullanılan güç kaynağının, ürünün üzerinde bulunan etikette belirtilen değerlere uygun olduğundan emin olun. Çalışma ortamını temiz tutun. Dağınık ve düzensiz alanlar yaralanmaya yol açabilir.
- 2- Çalışanların haricindeki kişilerin çalışma sahasından uzak tutulması gerekir. Başkalarının makineye veya uzatma kablosuna dokunmalarına izin vermeyin.
- 3- En iyi ve güvenilir sonucun makinenin tasarlandığı şekilde kullanılmasından elde edileceğini unutmayın.
- 4- Doğru makineyi kullandığınızdan emin olun. Küçük bir makineyi ağır bir iş için zorlamayın. Hiçbir makineyi amacı dışında kullanmayın. (Örneğin daire testereyi ağaç kesmek için kullanmak gibi..)
- 5- Çalışma giysilerinize dikkat edin. Bol giysiler ve takılar gibi makinenin hareketli parçalarına kapılabilecek giysiler giymeyin.
- 6- Koruyucu gözlük kullanın. Eğer toz çıkaran bir çalışma yapıyorsanız, yüz ya da toz maskesi kullanın.
- 7- Kabloyu amacı dışında yanlış yerlerde kullanmayın. Makineyi asla kablosundan tutarak taşımayın veya hızla prizden çekmeyin. Kabloyu kesici cisimlerden, sıcak yüzeylerden ve yağdan uzak tutun.
- 8- Çalışma alanı güç kaynağından uzak olduğunda, yeterli kalınlıkta ve belirtilen gücü kaldırabilen bir uzatma kablosu kullanın. Uzatma kablosu olabildiğince kısa tutulmalıdır.
- 9- Asla makinenizi kendiniz açmayınız ve tamir etmeye kalkışmayınız.
- 10- Herhangi bir arıza ya da bakım işlemi için kesinlikle yetkili servislerimizden biri ile temasa geçiniz (Bkz. arka kapak içi Servis ağı).
- 11- Tamiratlar yalnızca yetkili servis tarafından orijinal yedek parçalar kullanılarak yapılmalıdır. Yetkili olmayan kişilerce yapılacak müdahaleler garanti periyodundaki bir makinenin garantiden çıkmasına neden olacaktır.
- 12- Her türlü garantili onarım için fatura asıl veya kopyasını yetkili servise ibraz ediniz. Satış faturası ibraz edilmeyen makineler garanti kapsamı dışındadır.

## HITACHI ELEKTRİKLİ EL ALETLERİ HAKKINDA BİLMENİZ GEREKENLER

### Güvenlik

Çift izolasyonlu elektrikli el aletleri iç içe girmiş iki kare işareti (☐) ile sembolize edilir. Hitachi Elektrikli El Aletleri'nin tamamı çift izolasyon özelliğine sahip olup, bu özellik sayesinde harici bir topraklama olmadan ve oluşabilecek elektrik kaçaklarından etkilenmeden güvenli bir şekilde çalışabilirsiniz.

### ISO Sertifikaları

Bu katalogta bulunan tüm Hitachi Elektrikli El Aletleri ISO 9000 serisi uluslararası kalite uygunluk ve ISO 14000 çevre sertifikasına sahiptirler.

### CE Uygunluk Beyanı

Tüm Hitachi Elektrikli El Aletleri 73/23/EEC, 89/336/EC ve 98/37/EC sayılı Konsey Direktiflerine uygun olarak EN50144, EN55014 ve EN61000-3 sayılı standartlara uygundur.

## HITACHI ELEKTRİKLİ EL ALETLERİ

### Semboller ve Açıklamaları:

	Çift izolasyon		Eksantrik hareket		Yörüngesel hareket		12 Volt 50 dakikada şarj		18 Volt 40 dakikada şarj
	Elektronik yumuşak kalkış		Kavrama		Elektrikli fren		12 Volt 60 dakikada şarj		18 Volt 45 dakikada şarj
	Mil kilidi		Çantalı		3.6 Volt 30 dakikada şarj		14.4 Volt 22 dakikada şarj		18 Volt 50 dakikada şarj
	Elektronik hız kontrolü		İki vitesli		7.2 Volt 60 dakikada şarj		14.4 Volt 35 dakikada şarj		18 Volt 60 dakikada şarj
	Değişken hız		Değişken uç		10.8 Volt 30 dakikada şarj		14.4 Volt 40 dakikada şarj		18 Volt 75 dakikada şarj
	Sol-sağ dönüşlü		Anahtarsız mandren		10.8 Volt 35 dakikada şarj		14.4 Volt 60 dakikada şarj		24 Volt 60 dakikada şarj
	Şok emici kol		Otomatik stop tip kömür		10.8 Volt 40 dakikada şarj		14.4 Volt 75 dakikada şarj		25.2 Volt 60 dakikada şarj
	Toz emme		Emniyet debriyajı		12 Volt 35 dakikada şarj		18 Volt 35 dakikada şarj		36 Volt 80 dakikada şarj



### Ekolojik Ürünler

Sürdürülebilir bir toplum için, Hitachi Koki tasarım ve üretim aşamasında “Çevresel Etki Değerlendirmesi, ÇED” bilincine %100 uyumlu olarak hareket etmektedir. Bu konseptte üretilen ürünler “Ekolojik ürünler” olarak adlandırılmakta ve katalog içerisinde tescilli Hitachi Ekolojik ürün işareti ile sembolize edilmektedir. Bizler Ekolojik ürünlerin sayısını sürekli artırarak, yaşadığımız çevre ve toplumu koruma altına almaya çalışıyoruz.



UVP (User Vibration Protection), HITACHI Profesyonel Elektrikli El Aletleri'nin en son teknoloji ürünü düşük titreşimli çalışma sistemidir. Bu inovatif teknoloji sayesinde, HITACHI Profesyonel Elektrikli El Aletleri, özellikle kırıcı ve kırıcı-delici makinelerle yapılan uzun süreli çalışmalar sonucunda el, kol ve omuz bölgelerinde yüksek titreşimden kaynaklanan rahatsızlıklara karşı, korunma ve uzun süreli kullanım avantajı sunmaktadır.



IP “International Protection” yani “Uluslararası Koruma”, Uluslararası Elektroteknik Komisyon’u (IEC) tarafından geliştirilen bir standarttır. Bu standart elektrikli aletlerin, dış ortamdaki zararlı maddelerin, yabancı katı partiküllerin ve suyun makine içine nüfuziyetine karşı koruma derecesini belirtmektedir.

### IP kodların okunuşu:

**IP5 6**  
 5: dış ortamdaki suyun makine içine nüfuziyetine karşı koruma derecesi  
 6: dış ortamdaki zararlı maddelerin ve yabancı katı maddelerin makine içine nüfuziyetine karşı koruma derecesi



### 2016 Yılında Hitachi'ye 8. “iF Tasarım Ödülü”

“iF Tasarım Ödülü”, modern tasarımın doğduğu Almanya’da 1953 yılında verilmeye başlanmış, bugüne dünyanın en prestijli tasarım ödüllerinden biri olarak kabul edilen bir ödül haline gelmiştir. Aday ürünler değerlendirilirken sadece yaratıcılık, dış görünüm veya kullanım kolaylığı değil, performans, kalite, fiyat ve çevre duyarlılığı gibi kriterler de göz önünde bulundurulmaktadır.

2016 DH45ME ve DH52ME Kırıcı Delici

2015 H90SG Kırıcı

2013 CS33EDTP Elektrikli Zincir Testere

2009 CS33ET Elektrikli Zincir Testere ve WH14DBL Akülü Darbeli Vidalama

2006 H65SB2 ve H65SD2 Kırıcılar

2005 H25PV Kırıcı ve WH12DMR Akülü Darbeli Vidalama

2004 DH40MR Kırıcı-Delici ve WH12DM2 ve WH12DAF Akülü Darbeli Vidalama

2003 H45MR Kırıcı



## KÖMÜRSÜZ MOTORLAR

Kömürsüz motorlar (Brushless Motor) adından da anlaşılacağı gibi fiziksel temas ile sürtünme kaybına yol açan kömürleri içermezler. Sürekli mıknatıslar, dönen rotor üzerine monte edilmiş vaziyettedir ve stator bobinleri rotoru çevreleyecek şekilde yerleştirilmiştir. Elektronik komütasyon tekniği ile bobinler uygun zamanlama ile enerjilendirildiğinde rotor dönmeye başlar. Kömürsüz motorlarda elektronik kontrol ünitesi, rotor sargıları vasıtasıyla akım fazını değiştirerek, hassas bir dönme tepkisi alınması sağlar.

### KÖMÜRSÜZ MOTORUN AVANTAJLARI

- Motor kömür değişimi söz konusu olmadığından daha az bakım gerektirir.
- Sürtünme daha az olduğundan akülü uygulamalarda daha uzun batarya ömrü sunar.
- Daha fazla güç elde etme imkanı verir.
- Uzatma kablosuyla kullanımlarda minimum güç kaybı gerçekleşir.
- Jeneratör ile kullanıma daha uygundur.
- Kömürsüz motorlar yüklü ve yüksüz durumlarda kömürlü versiyonlara göre daha yüksek devirlerde çalışabilirler.
- Daha sessiz çalışırlar.

Tüm bunlar dikkate alındığında, özellikle profesyonel kullanıcılar için kalite ve uzun vadedeki maliyet açısından, doğru seçimin kömürsüz motorlar olduğu ve gelişen teknoloji ile trendin hızla bu yöne kaydığı açıkça görülmektedir.





**KALE**...

• Akülüler

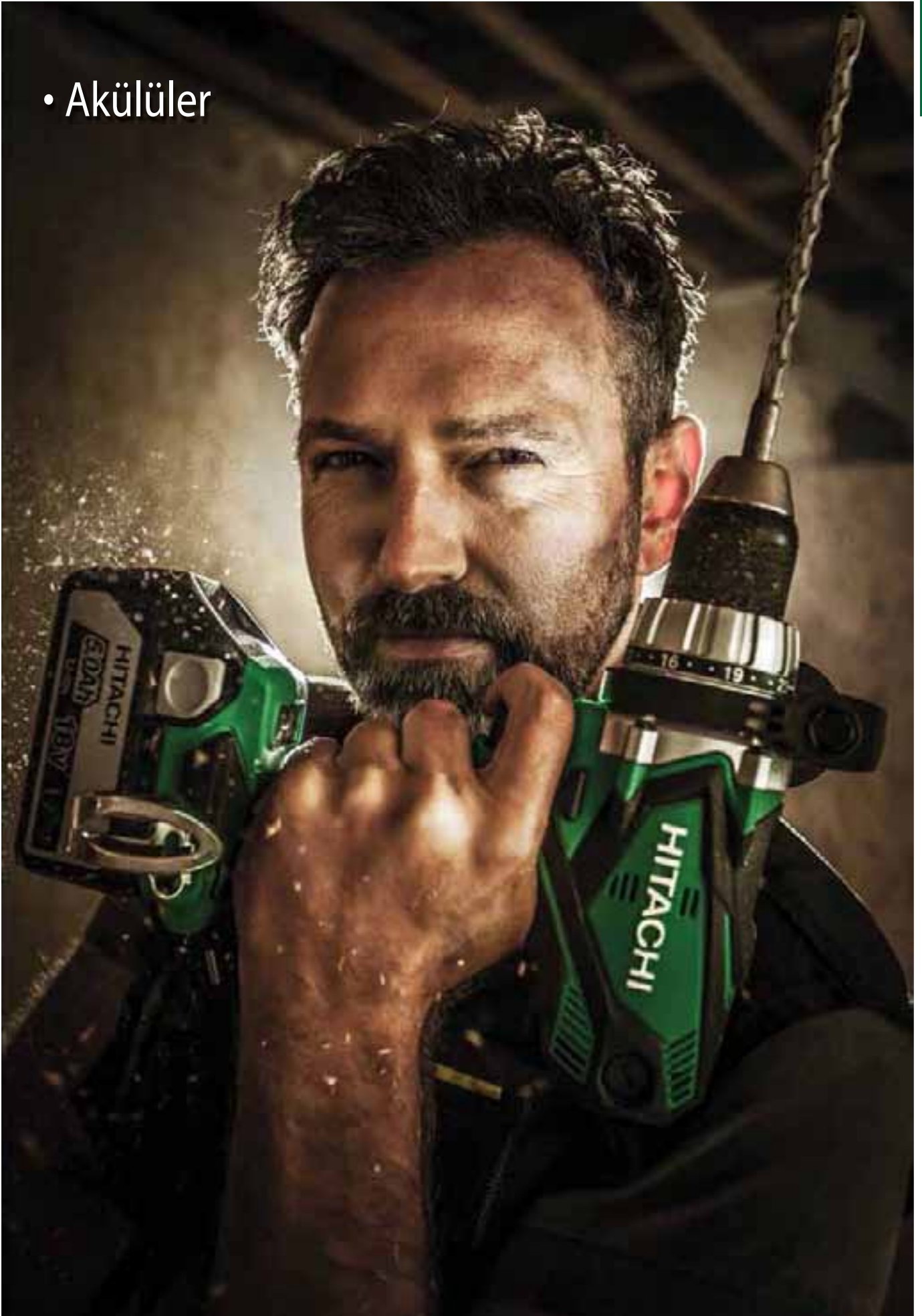

# Profesyonellerin tercihi

- Geniş ürün yelpazesi
- Ergonomik ve kompakt tasarım
- Ağır çalışma şartları ve yüksek güç için 18 V akü seçeneği
- Geniş akü kapasitesi seçeneği (1,5 Ah - 5 Ah)
- Yedek akü



**Li-ION  
BATTERY**

Ni-Cd akülere göre  
3 kat daha uzun ömür



## AKÜLÜ MATKAP VIDALAMALAR

1

### DS 10DAL 10.8 V / 1.5 Ah / 36 Nm Akülü Matkap Vidalama



- Kompakt, hafif ve dengeli yapı sadece 1 kg
- 10.8 V, 1.5 Ah yeni nesil Li-ion akü
- 21 kademe tork + delme kademesi
  - tork kademesi; 1-4.5 Nm tork aralığı
  - delme kademesi; 36 Nm maks. tork
- 2 vitesli hız seçimi
- 10 mm anahtarsız mandren, sağ-sol dönüş
- 30 dakikada hızlı şarj
- Led ışıklı aydınlatma

10.8v

1.5Ah  
Li-ion

MODEL	DS 10DAL
Akü voltajı	10.8 V
Akü kapasitesi	1.5 Ah
Şarj Süresi	30 dakika
Delme çapı	Çelik 10 mm Ahşap 29 mm
Vidalama	6 mm
Devir hızı	0-350/1300/dk
Tork ayarı	1-4.5 Nm
Ağırlık	21 kademe 1 kg



Li-ion  
BATTERY

185-\$

Standart aksesuarlar  
1 Çanta, 2 Akü, 1 Şarj makinası

### DS 14DFL 14.4 V / 1.5 Ah / 47 Nm Akülü Matkap Vidalama



- 14.4 V, 1.5 Ah yeni nesil Li-ion akü
- 22 kademe tork + delme kademesi
  - Tork kademesi; 1 - 6 Nm tork aralığı
  - Delme kademesi; 47 Nm maks. tork
- 2 vitesli hız seçimi
- 10 mm anahtarsız mandren, sağ-sol dönüş
- Elektrik fren tertibatlı elektronik hız ayarlı tetik
- Fan soğutmalı motor
- Hafif ve dengeli yapı

14.4v

1.5Ah  
Li-ion

MODEL	DS 14DFL
Akü voltajı	14.4 V
Akü kapasitesi	1.5 Ah
Şarj Süresi	40 dakika
Delme çapı	Çelik 12 mm Ahşap 30 mm
Vidalama	6 mm
Devir hızı	0-400/1200/dk
Tork ayarı	1-6 Nm
Ağırlık	22 kademe 1.6 kg



Li-ion  
BATTERY

210-\$

Standart aksesuarlar  
1 Çanta, 2 Akü, 1 Şarj makinası

### DS 14DSDL 14.4 V / 5.0 Ah / 82 Nm Akülü Matkap Vidalama



- Yeni nesil 14.4 V, 5.0 Ah Li-ion akü
- Ni-Cd akülere oranla üç kat daha uzun ömür
- 82 Nm maksimum tork
- 13 mm anahtarsız mandren
- 22 kademeli tork
- Daha yüksek güç ve dayanım için fan soğutmalı motor
- Dayanıklı alüminyum kasa
- 2 vitesli hız seçimi
- Akü göstergesi
- Led ışıklı aydınlatma
- 2.0 kg ağırlık

14.4v

5.0Ah  
Li-ion

MODEL	DS 14DSDL
Akü voltajı	14.4 V
Akü kapasitesi	5.0 Ah
Şarj Süresi	60 dakika
Delme çapı	Çelik 13 mm Ahşap 50 mm
Vidalama	6 mm
Devir	0-350/1600/dk
Tork ayarı	2-8 Nm
Ağırlık	22 kademe 2.0 kg



Li-ion  
BATTERY

365-\$

Standart aksesuarlar  
1 Çanta, 1 Tutamak  
2 Akü, 1 Şarj makinası

## AKÜLÜ MATKAP VIDALAMALAR

**DS 14DBSL** 14.4 V / 5.0 Ah / 60 Nm Akülü Matkap Vidalama

- Güçlü ve verimli kömürsüz Hitachi motoru
- Kömürlü motorlara göre daha az tamir ve bakım masrafı
- Kömürlü motorlara göre daha kompakt
- 5.0 Ah'lik akü kapasitesi ile kesintisiz güç
- 22 kademeli tork ayarı



14.4v

5.0Ah  
LI-ION

MODEL	DS 14DBSL
Akü voltajı	14.4 V
Akü kapasitesi	5.0 Ah
Şarj Süresi	75 dakika
Delme çapı	Çelik 13 mm Ahşap 50 mm
Sıkma Torku	35 / 60 Nm
Devir	0-350/1500/dk
Tork ayarı	1-4.5 Nm 22 kademe
Ağırlık	1.6 kg

BRUSH  
LESS  
MOTORLI-ION  
BATTERY

395-\$

Standart aksesuarlar  
1 Çanta, 2 Akü, 1 Şarj makinası

**DS 18DFL** 18V / 1.5Ah / 53 Nm Akülü Matkap Vidalama

- 18 V, 1.5 Ah yeni nesil Li-ion akü
- 22 kademe tork + delme kademesi  
- Tork kademesi; 1 - 6 Nm tork aralığı  
- Delme kademesi; 53 Nm maks. tork
- 2 vitesli hız seçimi
- 13 mm anahtarsız mandren,
- Sağ-sol dönüş
- Elektrik fren tertibatlı elektronik hız ayarlı tetik
- Fan soğutmalı motor
- Hafif ve dengeli yapı

18v

1.5Ah  
LI-ION

MODEL	DS 18DFL
Akü voltajı	18 V
Akü kapasitesi	1.5 Ah
Şarj Süresi	40 dakika
Delme çapı	Çelik 13 mm Ahşap 38 mm
Vidalama	6 mm
Devir hızı	0-400/1200/dk
Tork ayarı	1-6 Nm 22 kademe
Ağırlık	1.7 kg

LI-ION  
BATTERY

290-\$

Standart aksesuarlar  
1 Çanta, 2 Akü, 1 Şarj makinası

**DS 18DJL** 18 V, 1.5 Ah / 55 Nm Akülü Matkap Vidalama

- 18 V, 1.5 Ah yeni nesil Li-ion akü
- 22 kademe tork + delme kademesi  
- Tork kademesi; 1 - 6 Nm tork aralığı  
- Delme kademesi; 53 Nm maks. tork
- 2 vitesli hız seçimi
- 13 mm anahtarsız mandren,
- Sağ-sol dönüş
- Elektrik fren tertibatlı elektronik hız ayarlı tetik
- Fan soğutmalı motor
- Hafif ve dengeli yapı



18v

1.5Ah  
LI-ION

MODEL	DS 18DJL
Akü voltajı	18 V
Akü kapasitesi	1.5 Ah
Şarj Süresi	40 dakika
Delme çapı	Çelik 13 mm Ahşap 38 mm
Vidalama	6 mm
Devir hızı	0-450/1250/dk
Tork ayarı	1-6 Nm 22 kademe
Ağırlık	1.6 kg

LI-ION  
BATTERY

290-\$

Standart aksesuarlar  
1 Çanta, 2 Akü, 1 Şarj makinası

## AKÜLÜ MATKAP VIDALAMA

1

### DS 18DSDL 18 V / 5.0 Ah / 92 Nm Akülü Matkap Vidalama



- Yeni nesil 18 V, 5.0 Ah Li-ion akü
- Ni-Cd akülere oranla üç kat daha uzun ömür
- 92 Nm maksimum tork
- 13 mm anahtarsız mandren
- 22 kademeli tork
- Daha yüksek güç ve dayanım için fan soğutmalı motor
- Dayanıklı alüminyum kasa
- 2 vitesli hız seçimi
- Akü göstergesi
- Led ışıklı aydınlatma
- 2.1 kg ağırlık



18v

5.0Ah  
Li-ion

MODEL	DS 18DSDL
Akü voltajı	18 V
Akü kapasitesi	5.0 Ah
Şarj Süresi	60 dakika
Delme çapı	Çelik 13 mm Ahşap 65 mm
Vidalama	6 mm
Devir	0-350/1600/dk
Tork ayarı	2-8 Nm
Ağırlık	2.1 kg



Li-ion  
BATTERY

380-\$

Standart aksesuarlar  
1 Çanta, 1 Tutamak  
2 Akü, 1 Şarj makinası

### DS 18DBSL 18 V / 5.0 Ah / 70 Nm Akülü Matkap Vidalama



- Yeni nesil 18 V, 5.0 Ah Li-ion akü
- Ni-Cd akülere oranla üç kat daha uzun ömür
- 70 Nm maksimum tork
- 13 mm anahtarsız mandren
- 22 kademeli tork
- Güçlü ve verimli kömürsüz Hitachi motoru
- Kömür değiştirmeye son! Daha az tamir bakım masrafı
- Kömürlü motorlara göre daha kompakt
- 1.6 kg ağırlık



18v

5.0Ah  
Li-ion

MODEL	DS 18DBSL
Akü voltajı	18 V
Akü kapasitesi	5.0 Ah
Şarj Süresi	75 dakika
Delme çapı	Çelik 13 mm Ahşap 50 mm
Sıkma Torku	40 / 70 Nm
Devir	0-400/1800/dk
Tork ayarı	1-4.5 Nm
Ağırlık	1.6 kg



BRUSH  
LESS  
MOTOR

Li-ion  
BATTERY

420-\$

Standart aksesuarlar  
1 Çanta, 2 Akü, 1 Şarj makinası



## AKÜLÜ DARBELİ MATKAP VIDALAMALAR

**DV 14DSDL** 14.4 V / 5.0 Ah / 82 Nm Akülü Darbeli Matkap Vidalama

- Yeni nesil 14.4 V, 5.0 Ah Li-ion akü
- Ni-Cd akülere oranla üç kat daha uzun ömür
- 82 Nm maksimum tork
- 13 mm anahtarsız mandren
- 22 kademeli tork
- Daha yüksek güç ve dayanım için fan soğutmalı motor
- Dayanıklı alüminyum kasa
- 2 vitesli hız seçimi
- Akü göstergesi
- Led ışıklı aydınlatma
- 2.1 kg ağırlık

14.4v

5.0Ah  
LI-ION

MODEL	DV 14DSDL	
Akü voltajı	14.4 V	
Akü kapasitesi	5.0 Ah	
Şarj Süresi	60 dakika	
Delme çapı	Çelik	13 mm
	Ahşap	50 mm
Vidalama	6 mm	
Devir	0-350/1700/dk	
Tork ayarı	2-8 Nm	
	22 kademe	
Ağırlık	2.1 kg	

Li-ION  
BATTERY

380-Ş

Standart aksesuarlar  
1 Çanta, 1 tutamak  
2 Akü, 1 Şarj makinesi

**DV 18DJL** 18 V, 1.5 Ah / 55 Nm Akülü Darbeli Matkap Vidalama

- Yeni nesil 18 V, 1.5 Ah Li-ion akü
- 55 Nm sıkma torku
- 22 kademeli tork
- 2 vitesli hız seçimi
- 13 mm anahtarsız mandren



18v

1.5Ah  
LI-ION

MODEL	DV 18DJL	
Akü voltajı	18 V	
Akü kapasitesi	1.5 Ah	
Şarj Süresi	40 dakika	
Delme çapı	Çelik	13 mm
	Ahşap	38 mm
Vidalama	6 mm	
Devir hızı	0-350/1400/dk	
Tork ayarı	1-6 Nm	
	22 kademe	
Ağırlık	1.7 kg	

Li-ION  
BATTERY

310-Ş

Standart aksesuarlar  
1 Çanta, 2 Akü, 1 Şarj makinesi



## AKÜLÜ DARBELİ MATKAP VIDALAMALAR

1

### DV 18DSDL 18 V / 5.0 Ah / 92 Nm Akülü Darbeli Matkap Vidalama



- Yeni nesil 18 V, 5.0 Ah Li-ion akü
- Ni-Cd akülere oranla üç kat daha uzun ömür
- 92 Nm maksimum tork
- 13 mm anahtarsız mandren
- 22 kademeli tork
- Daha yüksek güç ve dayanım için fan soğutmalı motor
- Dayanıklı alüminyum kasa
- 2 vitesli hız seçimi
- Akü göstergesi
- Led ışıklı aydınlatma
- 2.2 kg ağırlık



18v

5.0Ah  
Li-ion

MODEL	DV 18DSDL	
Akü voltajı	18 V	
Akü kapasitesi	5.0 Ah	
Şarj Süresi	60 dakika	
Delme çapı	Çelik	13 mm
	Ahşap	65 mm
Vidalama	6 mm	
Devir	0-400/1800/dk	
Tork ayarı	2-8 Nm	
	22 kademe	
Ağırlık	2.2 kg	



Li-ion  
BATTERY

405- $\text{\$}$

Standart aksesuarlar  
1 Çanta, 1 Tutamak  
2 Akü, 1 Şarj makinası

### DV 18DBSL 18 V / 5.0 Ah / 70 Nm Akülü Darbeli Matkap Vidalama



- Yeni nesil 18 V, 5.0 Ah Li-ion akü
- Ni-Cd akülere oranla üç kat daha uzun ömür
- 70 Nm maksimum tork
- 13 mm anahtarsız mandren
- 22 kademeli tork
- Güçlü ve verimli kömürsüz Hitachi motoru
- Kömür değiştirmeye son! Daha az tamir bakım masrafı
- Kömürlü motorlara göre daha kompakt
- 1.7 kg ağırlık



18v

5.0Ah  
Li-ion

MODEL	DV 18DBSL	
Akü voltajı	18 V	
Akü kapasitesi	5.0 Ah	
Şarj Süresi	75 dakika	
Delme çapı	Çelik	13 mm
	Ahşap	50 mm
Sıkma Torku	40 / 70 Nm	
Devir hızı	0-400/1800/dk	
Darbe sayısı	0-6000/27000/dk	
Tork ayarı	1-4.5 Nm	
	22 kademe	
Ağırlık	1.7 kg	



BRUSH  
LESS  
MOTOR

Li-ion  
BATTERY

440- $\text{\$}$

Standart aksesuarlar  
1 Çanta, 2 Akü, 1 Şarj makinası





## AKÜLÜ VIDALAMA - AKÜLÜ DARBELİ KÖŞE MATKAP

**DB 3DL2** 3.6 V / 1.5 Ah / 5 Nm Akülü Vidalama

- Uzun ömürlü ve hafif Li-ion akü
- Led ışıklı aydınlatma
- 21 kademeli tork ayarı + delme kademesi
- 2 vitesli hız seçimi
- Akü şarj süresi 30 dakika
- Kaymayı önleyen yumuşak sap
- Kilitlenebilen mandreni ve katlanabilir yapısı sayesinde standard tornavida şeklinde kullanılabilen mükemmel tasarım

3.6V

1.5Ah  
Li-ion

MODEL	DB 3DL2
Akü voltajı	3.6 V
Akü kapasitesi	1.5 Ah
Şarj Süresi	30 dakika
Devir hızı	200/600/dk
Max sıkma torku	5 Nm
Uç girişi	1/4" altigen
Uzunluk	268 mm
Ağırlık	0.45 Kg

Li-ion  
BATTERY

135-\$

Standart aksesuarlar  
1 Çanta, 2 Akü, 1 Şarj makinası

**WH 10DCL** 10.8 V / 1.5 Ah / 30 Nm Akülü Darbeli Köşe Matkap

- Yeni nesil 10.8 V, 1.5 Ah Li-ion akü
- Maksimum sıkıştırma torku 30 Nm
- Düşük baş yüksekliği 53 mm
- Akü seviye göstergesi
- Led ışıklı aydınlatma



10.8V

1.5Ah  
Li-ion

MODEL	WH 10DCL
Akü voltajı	10.8 V
Akü kapasitesi	1.5 Ah
Şarj Süresi	40 dakika
Kapasite	Std. civata M4 - M10 mm Sert. civata M4 - M8 mm
Devir hızı	0-2100/dk
Darbe sayısı	0-3000/dk
Uç girişi	1/4" iç altigen
Ağırlık	1.0 kg

Li-ion  
BATTERY

320-\$

Standart aksesuarlar  
1 Çanta, 1 Uç  
1 Akü, 1 Şarj makinası



## AKÜLÜ DARBELİ VİDALAMALAR

1

### WH 10DAL 10.8 V / 1.5 Ah / 108 Nm Akülü Darbeli Vidalama



- Ergonomik tasarım, hafif ve dengeli yapı
- Rahat kullanım için ince sap, Ø 130 mm
- Sadece 1 kg ağırlığında
- Yeni nesil 10.8 V, 1.5 Ah Li-ion akü
- 108 Nm sıkma torku
- Led ışıklı aydınlatma



10.8V

1.5Ah  
Li-ion

MODEL	WH 10DAL
Akü voltajı	10.8 V
Akü kapasitesi	1.5 Ah
Şarj Süresi	30 dakika
Kapasite	Std. civata 4 - 8 mm Sert. civata 5 - 10 mm
Max. sıkma torku	108 Nm
Devir hızı	0-2700/dk
Darbe sayısı	0-3200/dk
Uç girişi	1/4" iç altıgen
Ağırlık	1.0 kg



Li-ion  
BATTERY

250-\$

Standart aksesuarlar

1 Çanta, 2 Akü, 1 Şarj makinesi

### WH 18DBDL2 18 V / 5.0 Ah / 207 Nm Akülü Darbeli Vidalama



- Yeni nesil 18V 5.0Ah Li-on Akü
- 207 Nm sıkma torku
- IP56 koruma sınıfı
- 4 kademeli devir ayar sistemi
- Düşük ve yüksek darbe ayarı imkanı
- Led ışıklı aydınlatma



18V

5.0Ah  
Li-ion

MODEL	WH 18DBDL2
Akü voltajı	18 V
Akü kapasitesi	5.0 Ah
Şarj Süresi	75 dakika
Kapasite	Std. civata 4 - 10 mm Sert. civata 3.5 - 6 mm
Max. sıkma torku	207 Nm
Devir hızı	0-2900/dk 0-2900/dk 0-900/dk 0-2900/dk
Darbe sayısı	0-2900/dk 0-900/dk 0-900/dk
Uç girişi	1/4" iç altıgen
Ağırlık	1.6 kg

IP56



Li-ion  
BATTERY

555-\$

Standart aksesuarlar

1 Çanta, 2 Akü, 1 Şarj makinesi



## AKÜLÜ DARBELİ SOMUN SIKMALAR

**WR 14DBDL2** 14 V / 5.0 Ah / 285 Nm Akülü Darbeli Somun Sıkma

14.4v

5.0Ah  
LI-ION

- Yeni nesil 14.4 V, 5.0 Ah Li-ion akü
- 285 Nm sıkma torku
- IP56 koruma sınıfı
- 4 kademeli devir ayar sistemi
- 1/2" Kare soket
- Led ışıklı aydınlatma

MODEL	WR 14DBDL2	
Akü voltajı	14.4 V	
Akü kapasitesi	5.0 Ah	
Şarj Süresi	32 dakika	
Sıkma kapasitesi	Std. civata	M10 - M20
	Sert civata	M10 - M16
Sıkma torku	285 Nm	
Devir hızı	1. mod	0-1000/dk
	2. mod	0-2000/dk
	3. mod	0-2600/dk
	Hassas	0-2600/dk
Darbe sayısı	0-3500/dk	
Uç girişi	1/2" kare soket	
Ağırlık	1.7 kg	

IP56

BRUSH  
LESS  
MOTORLI-ION  
BATTERY

580-\$



Standart aksesuarlar  
1 Çanta, 2 Akü, 1 Şarj makinası

**WR 18DBDL2** 18 V / 5.0 Ah / 305 Nm Akülü Darbeli Somun Sıkma

18v

5.0Ah  
LI-ION

- Yeni nesil 18 V, 5.0 Ah Li-ion akü
- 305 Nm sıkma torku
- IP56 koruma sınıfı
- 4 kademeli devir ayar sistemi
- 1/2" Kare soket
- Led ışıklı aydınlatma

MODEL	WR 18DBDL2	
Akü voltajı	18 V	
Akü kapasitesi	5.0 Ah	
Şarj Süresi	32 dakika	
Sıkma kapasitesi	Std. civata	M10 - M20
	Sert civata	M10 - M16
Sıkma torku	305 Nm	
Devir hızı	1. mod	0-1000/dk
	2. mod	0-2000/dk
	3. mod	0-2700/dk
	Hassas	0-2700/dk
Darbe sayısı	0-3600/dk	
Uç girişi	1/2" kare soket	
Ağırlık	1.8 kg	

IP56

BRUSH  
LESS  
MOTORLI-ION  
BATTERY

630-\$



Standart aksesuarlar  
1 Çanta, 2 Akü, 1 Şarj makinası

**WR 18DSHL** 18 V / 3.0 Ah / 480 Nm Akülü Darbeli Somun Sıkma

18v

3.0Ah  
LI-ION

- 18 V, 3.0 Ah yeni nesil Li-ion akü
- Sıkma ve gevşetme için kullanımı rahat büyük tetik
- 480 Nm sıkma kapasitesi
- 1/2" Kare soket
- Led ışıklı aydınlatma

MODEL	WR 18DSHL	
Akü voltajı	18 V	
Akü kapasitesi	3.0 Ah	
Şarj Süresi	60 dakika	
Kapasite	Std. civata	12 - 22 mm
	Sert civata	12 - 16 mm
Sıkma torku	480 Nm	
Devir hızı	0-1500/dk	
Darbe sayısı	0-2000/dk	
Uç girişi	1/2" kare soket	
Ağırlık	3.4 kg	

LI-ION  
BATTERY

825-\$

Standart aksesuarlar  
1 çanta, 2 akü, 1 şarj makinası

## AKÜLÜ KIRICI DELİCİLER - AKÜLÜ BASINÇLI YIKAMA

1

### DH 18DBL 26 mm / 18 V / 5.0 Ah Akülü Kırıcı Delici



18 v

5.0Ah  
Li-Ion

- 3 mod (Delme, darbeli delme, kırıcı)
- SDS-Plus uç sistemi
- 5 Ah'lik güçlü Li-Ion Akü

MODEL	DH 18DBL	
Akü voltajı	36.0V	
Akü kapasitesi	5.0 Ah	
Şarj Süresi	75 dakika	
Kapasite	Beton	26 mm
	Çelik	13 mm
Devir hızı	0-1050/dk	
Darbe sayısı	0-3950/dk	
Darbe kuvveti	2.6 Joule	
Ağırlık	3.7 kg	
Uç tipi	SDS-plus	



2.6  
JOULE  
DARBE KUVVETİ

BRUSH  
LESS  
MOTOR

Li-Ion  
BATTERY

690-\$

Standart aksesuarlar

- 1 Çanta, 1 Tutamak, 1 Derinlik Mastarı  
2 Akü,, 1 Şarj makinası

### DH 36DBL 28 mm / 36 V / 2.6 Ah Akülü Kırıcı Delici



36 v

2.6Ah  
Li-Ion

- Sınıfının tek kömürsüz akülü kırıcı-delicisi
- 3 mod (Delme, darbeli delme, kırıcı)
- SDS-Plus uç sistemi
- 2.6 Ah'lik güçlü Li-Ion Akü

MODEL	DH 36DBL	
Akü voltajı	36.0V	
Akü kapasitesi	2.6 Ah	
Şarj Süresi	80 dakika	
Kapasite	Beton	28 mm
	Çelik	13 mm
Devir hızı	1100/dk	
Darbe sayısı	4300/dk	
Darbe kuvveti	3.3 Joule	
Ağırlık	4.8 kg	
Uç tipi	SDS-plus	



3.3  
JOULE  
DARBE KUVVETİ

BRUSH  
LESS  
MOTOR

Li-Ion  
BATTERY

1.150-\$

Standart aksesuarlar

- 1 Çanta, 1 Tutamak, 1 Derinlik Mastarı  
2 Akü,, 1 Şarj makinası

### AW 18DBL 20 bar / 18 V / 5.0 Ah Akülü Basınçlı Yıkama



18v

5.0Ah  
Li-Ion

- Sınıfının tek akülü basınçlı yıkama makinesi
- 5.0 Ah'lik güçlü akü kapasitesi
- Ergonomik ve kompakt yapısı sayesinde lazım olan her yerde yanınızda
- Klima servisleri ve outdoor spor tutkunları için ideal
- Kömürsüz motor teknolojisi ile yüksek performans ve düşük tamir bakım masrafı

MODEL	AW 18DBL	
Ürün Kodu	89AW18DBL	
Akü Voltajı	18 V	
Akü Kapasitesi	5.0 Ah	
Şarj Süresi	35 dk	
Maksimum Basınç	20 bar	
Tank kapasitesi	8 litre	
Su sıcaklığı	40°C ce daha düşük	
Ağırlık	4,5 kg	



BRUSH  
LESS  
MOTOR

Li-Ion  
BATTERY

890-\$

Standart aksesuarlar

- 1 adet yıkama tabancası, hortum, çeşitli nozuller, nozul açıcı pim  
1 Akü,, 1 Şarj makinası

## AKÜLÜ DEKUPAJ - AKÜLÜ TILKI KUYRUKLARI

**CJ 14DSL** 135 mm / 14.4 V / 3.0 Ah Akülü Dekupaj

- Yeni nesil 14.4 V, 3.0 Ah Li-ion akü
- 45 derece sağ-sol kesim
- 3 kademeli yörüngesel hareket
- Yumuşak ve kullanışlı tutamak
- Anahtarsız bıçak değiştirme
- Led ışıklı aydınlatma
- Akü seviye göstergesi



14.4v

3.0Ah  
LI-ION

MODEL	CJ 14DSL	
Akü voltajı	14.4 V	
Akü kapasitesi	3.0 Ah	
Şarj Süresi	60 dakika	
Kesme derinliği	Ahşap	135 mm
	Çelik	10 mm
Devir hızı	0-2400/dk	
Strok uzunluğu	26 mm	
Ağırlık	2.3 kg	

Li-ION  
BATTERY535-**\$**

Standart aksesuarlar

1 Çanta, 1 Anahtar, 1 Bıçak  
2 Akü, 1 Şarj makinesi**CR 10DL** 25 mm / 10.8 V / 1.5 Ah Akülü Tilki Kuyruğu

- Yeni nesil 10.8 V, 1.5 Ah Li-ion akü
- 40 dakikada hızlı şarj
- Ergonomik tutamak
- Değişken kontrollü kesim hızı
- Anahtarsız kolay bıçak değiştirme
- Led ışıklı aydınlatma



10.8v

1.5Ah  
LI-ION

MODEL	CR 10DL	
Akü voltajı	10.8 V	
Akü kapasitesi	1.5 Ah	
Şarj Süresi	40 dakika	
Kesme Kapasitesi	Boru	25 mm
	Çelik Levha	4 mm
	Ahşap	50 mm
Strok boyu	13 mm	
Devir hızı	0-2700/dk	
Uzunluk	349 mm	
Ağırlık	1.2 kg	

Li-ION  
BATTERY270-**\$**

Standart aksesuarlar

1 Çanta, 1 Anahtar, 1 Bıçak  
1 Akü, 1 Şarj makinesi**CR 18DSL** 90 mm / 18 V / 3.0 Ah Akülü Tilki Kuyruğu

- Anahtarsız kolay değiştirilebilen bıçak mekanizması
- Değiştirilebilen endüvi ve kömürler
- Rahat kullanım için kauçuk gövde ve sap
- Güvenlik kilitli, değişken hız kontrollü kullanımı kolay büyük tetik
- Akü seviye göstergesi

18v

3.0Ah  
LI-ION

MODEL	CR 18DSL	
Akü voltajı	18 V	
Akü kapasitesi	3.0 Ah	
Şarj Süresi	45 dakika	
Kesme Kapasitesi	Boru	90 mm
	Çelik Levha	10 mm
	Ahşap	90 mm
Strok boyu	28 mm	
Devir hızı	0-2100/dk	
Uzunluk	434 mm	
Ağırlık	3.4 kg	

Li-ION  
BATTERY550-**\$**

Standart aksesuarlar

1 Çanta, 1 Anahtar, 1 Bıçak  
2 Akü, 1 Şarj makinesi

## AKÜLÜ AVUÇ TAŞLAMALAR

1

### G 14DSL 115 mm / 14.4 V / 3.0 Ah Akülü Avuç Taşlama



- Yeni nesil 14.4 V, 3.0 Ah Li-ion bataryası sayesinde hafif ve dengeli yapı; sadece 1.9 kg
- Kompakt ve ince gövde 182 mm kavrama çapı
- Değiştirilebilen endüvi ve kömürler sayesinde uzun ömürlü çalışma imkanı
- Kullanımı kolay yandan tetik
- Akü seviye göstergesi

14.4v

3.0Ah  
Li-ion



MODEL	G 14DSL
Akü voltajı	14.4 V
Akü kapasitesi	3.0 Ah
Şarj Süresi	45 dakika
Disk çapı	115 mm
Mil vidası	M14x2
Devir hızı	9300/dk
Ağırlık	1.7 kg

Li-ion  
BATTERY

450-₺

Standart aksesuarlar

1 Çanta, 1 Tutamak, 1 Anahtar  
2 Akü, 1 Şarj makinası

### G 18DSL 115 mm / 18 V / 3.0 Ah Akülü Avuç Taşlama



- Yeni nesil 18 V, 3.0 Ah Li-ion bataryası
- Hafif ve dengeli yapı; sadece 1.9 kg
- Kompakt ve ince gövde 182 mm kavrama çapı
- Değiştirilebilen endüvi ve kömürler sayesinde uzun ömürlü çalışma imkanı
- Kullanımı kolay yandan tetik
- Akü seviye göstergesi



18v

3.0Ah  
Li-ion



MODEL	G 18DSL
Akü voltajı	18.0 V
Akü kapasitesi	3.0 Ah
Şarj Süresi	45 dakika
Disk çapı	115 mm
Mil vidası	M14x2
Devir hızı	9100/dk
Ağırlık	1.8 kg

Li-ion  
BATTERY

505-₺

Standart aksesuarlar

1 Çanta, 1 Tutamak, 1 Anahtar  
2 Akü, 1 Şarj makinası

### G 18DBL 115 mm / 18 V / 5.0 Ah Akülü Avuç Taşlama



- Yeni nesil 18 V, 5.0 Ah Li-ion bataryası
- 152 mm gövde çapı
- Sesi ve titreşimi düşüren özel fonksiyon



18v

5.0Ah  
Li-ion



MODEL	G 18DBL
Akü voltajı	18.0 V
Akü kapasitesi	5.0 Ah
Şarj Süresi	75 dakika
Disk çapı	115 mm
Mil vidası	M14x2
Devir hızı	9000/dk
Ağırlık	2.3 kg

BRUSH  
LESS  
MOTOR

Li-ion  
BATTERY

575-₺

Standart aksesuarlar

1 Çanta, 1 Tutamak, 1 Anahtar  
2 Akü, 1 Şarj makinası

- Matkaplar
- Karıştırıcılar
- Elektrikli tornavidalar
- Darbeli somun sıkımlar



## DARBESİZ MATKAP - KÖŞE MATKAP

### D 10VC3 10 mm / 600 W Darbesiz Matkap



2

- Güçlü motor 600 W
- Düşük titreşim ve sessiz çalışma
- 10 mm anahtarsız mandren
- Ergonomik tasarım
- Güvenli ve rahat tutuş için yumuşak sap
- Devir sayısı ön seçimi
- Sağ-sol dönüş



MODEL	D 10VC3
Mandren kapasitesi	1-10 mm
Çelikte delme çapı	10 mm
Ahşapta delme çapı	25 mm
Güç	600 W
Devir sayısı	0-2500/dk
Uzunluk	238 mm
Ağırlık	1.4 kg



72-<sup>§</sup>

### D 13VL 13mm / 860 W Darbesiz Matkap



- 860 W'lık güçlü Hitachi Motoru
- Sağlam alüminyum gövde (AHB)
- "Slip Clutch" teknolojisi ile aşırı yüklenmelerde dişli sıyırmasına son
- Ergonomik yan tutamak ve kabza



MODEL	D 13VL
Mandren kapasitesi	1-13 mm
Çelikte delme çapı	13 mm (düşük hız) 8 mm (yüksek hız)
Ahşapta delme çapı	40 mm (düşük hız) 25 mm (yüksek hız)
Güç	860 W
Devir sayısı	0-1100/3000/dk
Ağırlık	2.9 kg



220-<sup>§</sup>

Standart aksesuarlar:  
1 Tutamak, 1 Derinlik mastarı

### D 10YB 10 mm / 500 W Köşe Matkap



- Düşük baş yüksekliği, 83 mm
- 500 W güçlü motor
- 10 mm mandren kapasitesi
- Kullanımı rahat büyük tetik
- Sağ-sol dönüş
- Elektronik hız kontrolü



MODEL	D 10YB
Mandren kapasitesi	1-10 mm
Çelikte delme çapı	10 mm
Ahşapta delme çapı	22 mm
Güç	500 W
Devir sayısı	500-2300/dk
Uzunluk	290 mm
Ağırlık	1.5 kg



410-<sup>§</sup>

Standart aksesuarlar:  
1 Mandren anahtarı, 1 Tutamak



## DARBELİ MATKAPLAR

**FDV 16VB2** 13 mm / 550 W Darbeli Matkap

- 13 mm anahtarsız mandren
- Yenilenmiş rulmanlı yataklama
- Güvenli tutuş için yumuşak tutamak
- Devir sayısı ön seçimi
- Sağ-sol dönüş

MODEL	FDV 16VB2
Mandren kapasitesi	1.5-13 mm
Betonda delme çapı	16 mm
Çelikte delme çapı	13 mm
Ahşapta delme çapı	25 mm
Güç	550 W
Devir sayısı	0-2900/dk
Uzunluk	289 mm
Ağırlık	1.6 kg



78-\$

Standart aksesuarlar:  
1 Çanta, 1 Tutamak, 1 Derinlik Mastarı

**DV 16VSS** 13 mm / 600 W Darbeli Matkap

- 600 W güçlü motor
- 1.5 - 13 mm anahtarsız mandren
- Kompakt ve hafif, sadece 1.5 kg
- Tetikten ayarlanabilen hassas devir ayarı
- Sağ-sol dönüş



MODEL	DV 16VSS
Mandren kapasitesi	1.5-13 mm
Betonda delme çapı	16 mm
Çelikte delme çapı	13 mm
Ahşapta delme çapı	25 mm
Güç	600 W
Devir sayısı	0-2900/dk
Uzunluk	270 mm
Ağırlık	1.5 kg



88-\$

Standart aksesuarlar:  
1 Çanta, 1 Tutamak, 1 Derinlik mastarı

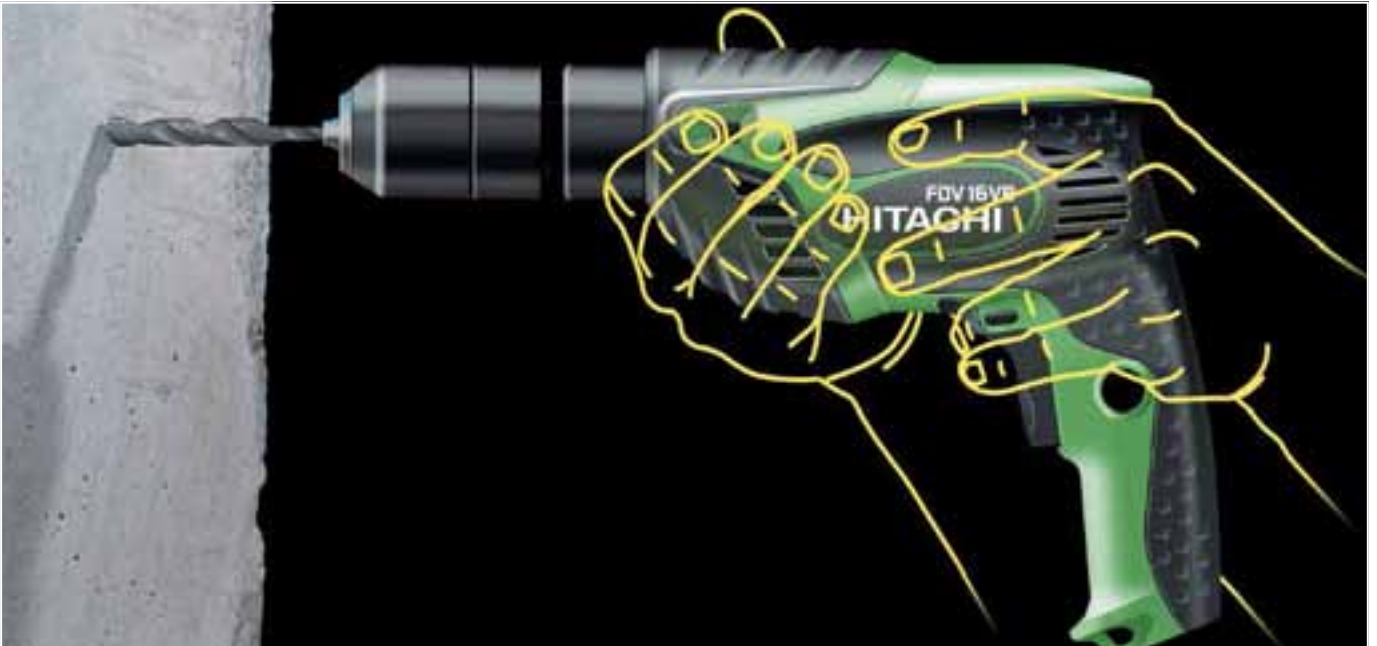

## DARBELİ MATKAPLAR

### DV 18V 13 mm / 690 W Darbeli Matkap



- 690 W güçlü Hitachi motoru
- 13 mm anahtarlı mandren
- 2 vitesli şanzıman
- Hafif ve kompakt yapı
- Devir sayısı ön seçimi
- Sağ-sol dönüş
- Güvenli ve rahat tutuş için yumuşak sap

MODEL	DV 18V
Mandren kapasitesi	13 mm
Betonda delme çapı	18/13 mm
Çelikte delme çapı	13/8 mm
Ahşapta delme çapı	40/25 mm
Güç	690 W
Devir sayısı	0-1000/3000/dk
Uzunluk	333 mm
Ağırlık	2 kg



145-Ş

Standart aksesuarlar:

1 Çanta, 1 Tutamak, 1 Derinlik mastarı, 1 mandren anahtarı

### DV 20VD 13 mm / 860 W Darbeli Matkap



- 860 W'lık güçlü Hitachi Motoru
- Sağlam alüminyum gövde (AHB)
- "Slip Clutch" teknolojisi ile aşırı yüklenmelerde dişli sıyırmasına son
- Ergonomik yan tutamak ve kabza

MODEL	DV 20VD
Mandren kapasitesi	1-13 mm
Betonda delme çapı	20/13 mm
Çelikte delme çapı	13/8 mm
Ahşapta delme çapı	40/25 mm
Güç	860 W
Devir sayısı	0-1100/3000/dk
Ağırlık	3 kg



255-Ş

Standart aksesuarlar:

1 Çanta, 1 Tutamak, 1 Derinlik mastarı

### DV 22V 13 mm / 1120 W Darbeli Matkap



- 1120 W'lık güçlü Hitachi Motoru
- Sağlam alüminyum gövde (AHB)
- "Slip Clutch" teknolojisi ile aşırı yüklenmelerde dişli sıyırmasına son
- Ergonomik yan tutamak ve kabza

MODEL	DV22V
Mandren kapasitesi	1-13 mm
Betonda delme çapı	22/13 mm
Çelikte delme çapı	13/8 mm
Ahşapta delme çapı	40/25 mm
Güç	1120 W
Devir sayısı	0-1100/3000/dk
Ağırlık	3 kg



275-Ş

Standart aksesuarlar:

1 Çanta, 1 Tutamak, 1 Derinlik mastarı

## DARBELİ MATKAP

**VTV 16** 16 mm / 800 W Darbeli Matkap

- 2 vitesli şanzıman
- Sağlam metal gövde
- Güçlü motor; büyük çaplı delikler ve karıştırma işleri için ideal
- 16 mm anahtarlı mandren
- Devir sayısı ön seçimi
- 360° çevrilebilir yan tutamak

MODEL	VTV 16
Mandren kapasitesi	3.2-16 mm
Betonda delme çapı	35/16 mm
Çelikte delme çapı	16/10 mm
Ahşapta delme çapı	50/40 mm
Güç	800 W
Devir sayısı	0-700/1400/dk
Uzunluk	443 mm
Ağırlık	3.8 kg

**490-Ş**

## KARIŐTIRICILAR

### UM 12VST 120 mm / 1100 W Kariőtirici



- 1100 W motor
- 2 vitesli Őanzıman
- Saęlam metal Őanzıman kutusu
- YumuŐak kalkıŐ
- Elektronik sabit hız kontrol sistemi
- Darbelere karŐı dayanıklı koruma barları

#### Kariőtirici Aparat

ÜRÜN KODU	ÖLÇÜ	FİYAT
333603	Ø 120 mm	11,00-€

Standart aksesuarlar:  
1 kariőtirici uç, 1 anahtar

MODEL	UM12VST
Güç	1100 W
Mil çıkıŐı	M 14
Devir sayısı (2 vites)	300-650/dk
Devir sayısı (1 vites)	150-300 dev/dk
Kariőtirici aparat çapı	120 mm
Aęirlik	5.4 kg



215-Ő

### UM 16VST 160 mm / 1500 W Kariőtirici



- 1500 W motor
- 2 vitesli Őanzıman
- Saęlam metal gövde
- YumuŐak kalkıŐ
- Elektronik sabit hız kontrol sistemi
- Darbelere karŐı dayanıklı koruma barları

#### Kariőtirici Aparat

ÜRÜN KODU	ÖLÇÜ	FİYAT
333639	Ø 160 mm	14,00-€

Standart aksesuarlar:  
1 kariőtirici uç, 1 anahtar

MODEL	UM16VST
Güç	1500 W
Mil çıkıŐı	M 14
Devir sayısı (2 vites)	300-650/dk
Devir sayısı (1 vites)	150-300 dev/dk
Kariőtirici aparat çapı	160 mm
Aęirlik	5.6 kg



240-Ő



## ELEKTRİKLİ TORNAVİDALAR

**W 6VA4** 620 W / 3000 dev/dk Elektrikli Tornavida

- Civata başlı vidaları sıkmak için ideal yüksek devir; 0-3000 dev/dk
- Kablo uzunluğu 7.5 metre
- Tetiğe kolay ulaşılabilmeyi sağlayan ele rahat oturan sınıftaki en kısa kavrama mesafesi
- Tek hareketle vida derinlik ayarı
- Güçlendirilmiş alüminyum dış ve iç kapak
- Alüminyum durdurucu kılavuz
- Sağ-sol dönüş, elektronik devir ayarlı tetik



MODEL	W 6VA4
Güç	620 W
Uç girişi	1/4" iç altıgen
Vidalama çapı	6 mm
Devir sayısı	0-3000/dk.
Ağırlık	1.4 kg
Kablo uzunluğu	7.5 m

**185-\$**

Standart aksesuarlar:

1 Manyetik uç tutucu, PH2 Yıldız bits uç

**W 6V4** 620 W / 4500 dev/dak Elektrikli Tornavida

- Civata başlı vidaları sıkmak için ideal yüksek devir; 0-4500 dev/dak
- Kablo uzunluğu 7.5 metre
- Tetiğe kolay ulaşılabilmeyi sağlayan ele rahat oturan sınıftaki en kısa kavrama mesafesi
- Tek hareketle vida derinlik ayarı
- Güçlendirilmiş alüminyum dış ve iç kapak
- Alüminyum durdurucu klavuz
- Sağ-sol dönüş, elektronik devir ayarlı tetik



MODEL	W 6V4
Güç	620 W
Uç girişi	1/4" iç altıgen
Vidalama çapı	6 mm
Devir sayısı	0-4500/dk.
Ağırlık	1.4 kg
Kablo uzunluğu	7.5 m

**195-\$**

Standart aksesuarlar:

1 Manyetik uç tutucu, PH2 Yıldız bits uç

**W 6VM** 620 W / 6000 dev/dk Elektrikli Tornavida

- Civata başlı vidaları sıkmak için ideal yüksek devir; 0-6000 dev/dk
- Kablo uzunluğu 7.5 metre
- Tetiğe kolay ulaşılabilmeyi sağlayan ele rahat oturan sınıftaki en kısa kavrama mesafesi
- Tek hareketle vida derinlik ayarı
- Güçlendirilmiş alüminyum dış ve iç kapak
- Alüminyum durdurucu kılavuz
- Sağ-sol dönüş, elektronik devir ayarlı tetik



MODEL	W 6VM
Güç	620 W
Uç girişi	1/4" iç altıgen
Vidalama çapı	6 mm
Devir sayısı	0-6000/dk
Ağırlık	1.4 kg
Kablo uzunluğu	7.5 m

**205-\$**

Standart aksesuarlar:

1 Manyetik uç tutucu, PH2 Yıldız bits uç

## Üstün özelliklere sahip kömürsüz motorlu yeni nesil somun sıkma makinesi

### Tampon

Çekiç kutusunu korur.

### Elektronik tetik

Daha az çekme kuvveti ve yumuşak strok ile daha iyi kontrol.

### Yumuşak kavrama

Kaymayı önleyip ele iyi oturan tasarım.

Sıkma torku  
**250 Nm**

Sıkma modu değiştirme düğmesi

Askı kancası

### Dış muhafaza

Çevresel koruma sağlar.

\* Lokma pakete dahil değildir.

# WR 14VE



14 mm (9/16") kömürsüz motorlu elektrikli darbeli somun sıkma makinesi

### Tampon

Çekiç kutusunu korur.

### Yeni tetik

**Mandal tipli ileri/geri tetik**  
İleri - geri modları arasında hızlı geçişe izin verir.

### Yumuşak kavrama

Kaymayı önleyip ele iyi oturan tasarım.

Sıkma torku  
**360 Nm**

Sıkma modu değiştirme düğmesi

Askı kancası

### Dış muhafaza

Çevresel koruma sağlar.

\* Lokma pakete dahil değildir.

# WR 16SE



16 mm (5/8") kömürsüz motorlu elektrikli darbeli somun sıkma makinesi

## DARBELİ SOMUN SIKMALAR

**WR 14VE** 250 Nm / 370 W Darbeli Somun Sıkma

- Güçlü Hitachi motoru 370 W
- Kömürlü motorlara göre %30 daha fazla çalışma süresi
- Sınıfında en yüksek sıkma torku 250 Nm
- Kaymayan, rahat ve yumuşak tutamak
- Elektronik devir ayarlı tetik
- Kullanımı rahat sağ-sol dönüş düğmesi
- Yüksek-düşük hız seçme modu

**Üçlü Pim + O-ring**

ÜRÜN KODU	FİYAT
751877	1,71-\$
751876	1,55-\$

Standart aksesuarlar:  
1 Bel askı kancası, 1 Çanta



MODEL	WR 14VE	
Kapasite	M10-M18	
Soket	12.7 mm (1/2" kare)	
Sıkma torku	185-250 Nm	
Güç	370 W	
Devir sayısı	1. mod	0-1400/dk
	2. mod	0-1600/dk
	3. mod	0-1800/dk
	4. mod	0-2100/dk
Darbe sayısı	1. mod	0-1500/dk
	2. mod	0-1900/dk
	3. mod	0-2300/dk
	4. mod	0-2700/dk
Ağırlık	2.0 kg	

**490-\$****WR 16SE** 360 Nm / 370 W Darbeli Somun Sıkma

- Yenilenmiş yapısı sayesinde uzun ömürlü kullanım
- Kömürlü motorlara göre %30 daha fazla çalışma süresi
- Güçlü Hitachi motoru 370 W
- Sınıfında en yüksek sıkma torku 360 Nm
- Kaymayan, rahat ve yumuşak tutamak
- Sıkma ve gevşetme için kullanımı rahat sağ-sol dönüş
- Ön tarafta geniş koruyucu tampon

**Üçlü Pim + O-ring**

ÜRÜN KODU	FİYAT
751877	1,71-\$
751876	1,55-\$

Standart aksesuarlar:  
1 Bel askı kancası, 1 Çanta



MODEL	WR 16SE	
Kapasite	M12-M22	
Soket	12.7 mm (1/2" kare)	
Sıkma torku	360 Nm	
Güç	370 W	
Devir sayısı	1. mod	0-1100/dk
	2. mod	0-1300/dk
	3. mod	0-1400/dk
	4. mod	0-1600/dk
Darbe sayısı	1. mod	0-1300/dk
	2. mod	0-1500/dk
	3. mod	0-1700/dk
	4. mod	0-1900/dk
Ağırlık	2.5 kg	

**520-\$**

# Profesyonellerin tercihi

**WR 22SE**  
**WR 25SE**

*Kendi Sınıfının*

**EN KÜÇÜK,  
EN HAFİF ve TEK  
Kömürsüz Motorlu  
Darbeli Somun Sıkma  
Makinesi**

**AHB**  
ALUMINIUM HOUSING BODY

**BRUSH  
LESS  
MOTOR**







## IF Tasarım Ödülleri ürün kategorisinde “Tasarım Mükemmelliği” ödülü sahibi



Sıkma  
Torku  
**620**  
Nm

Alternatif Akım  
Gücü ile çalışan

**WR 22SE**  
**22mm**

WR 22SE

Toplam Uzunluk  
**280**mm

**23**mm Daha  
Kısa  
Eski model WR22SA'ya göre

Toplam Ağırlık  
**4.6**kg

**0.2**kg Daha  
Hafif  
Eski model WR22SA'ya göre



Sıkma  
Torku  
**1,000**  
Nm

Alternatif Akım  
Gücü ile çalışan

**WR 25SE**  
**25mm**

Toplam Uzunluk  
**340**mm

**97**mm Daha  
Kısa  
Eski model WH25'e göre

Toplam Ağırlık  
**7.7**kg

**1.3**kg Daha  
Hafif  
Eski model WH25'e göre

### WR 22SE 620 Nm / 800 W Darbeli Somun Sıkma



- Kömürsüz motorlu yenilikçi teknoloji
- Kendi sınıfının en küçük ve en hafifi
- Sağlam ve uzun ömürlü alüminyum gövde
- Kömürsüz motoru sayesinde voltaj düşüşlerinde dahi performansını korur
- Jeneratör ile çalışmaya uygun
- Ön ve arka tamponlar gövdeyi darbeleri karşı korur.
- Yumuşak ve ergonomik tutamak

MODEL	WR 22SE
Kapasite	M14-M24
Soket	19 mm (3/4")
Sıkma Torku	620 Nm
Güç	800 W
Darbe Sayısı	2000/dk
Devir Sayısı	1400/dk
Ağırlık	4.6 Kg



740-Ş

Standart aksesuarlar:  
1 Tutamak, 1 adet çanta

### WR 25SE 1000 Nm / 900 W Darbeli Somun Sıkma



- Kömürsüz motorlu yenilikçi teknoloji
- Kendi sınıfının en ergonomiği
- Sağlam ve uzun ömürlü alüminyum gövde
- Kömürsüz motoru sayesinde voltaj düşüşlerinde dahi performansını korur
- Jeneratör ile çalışmaya uygun
- Ön ve arka tamponlar gövdeyi darbelere karşı korur
- Yumuşak ve ergonomik tutamak

MODEL	WR 25SE
Kapasite	M22-M30
Soket	25,4 mm (1")
Sıkma Torku	1000 Nm
Güç	900 W
Darbe Sayısı	1500/dk
Devir Sayısı	1100/dk
Ağırlık	7.7 Kg



1.030-Ş

Standart aksesuarlar:  
1 Tutamak, 1 adet çanta



**KALE**<sub>III</sub>

- Avuç taşlamalar
- Büyük taşlamalar
- Polisaj
- Kalıpcı taşlamalar

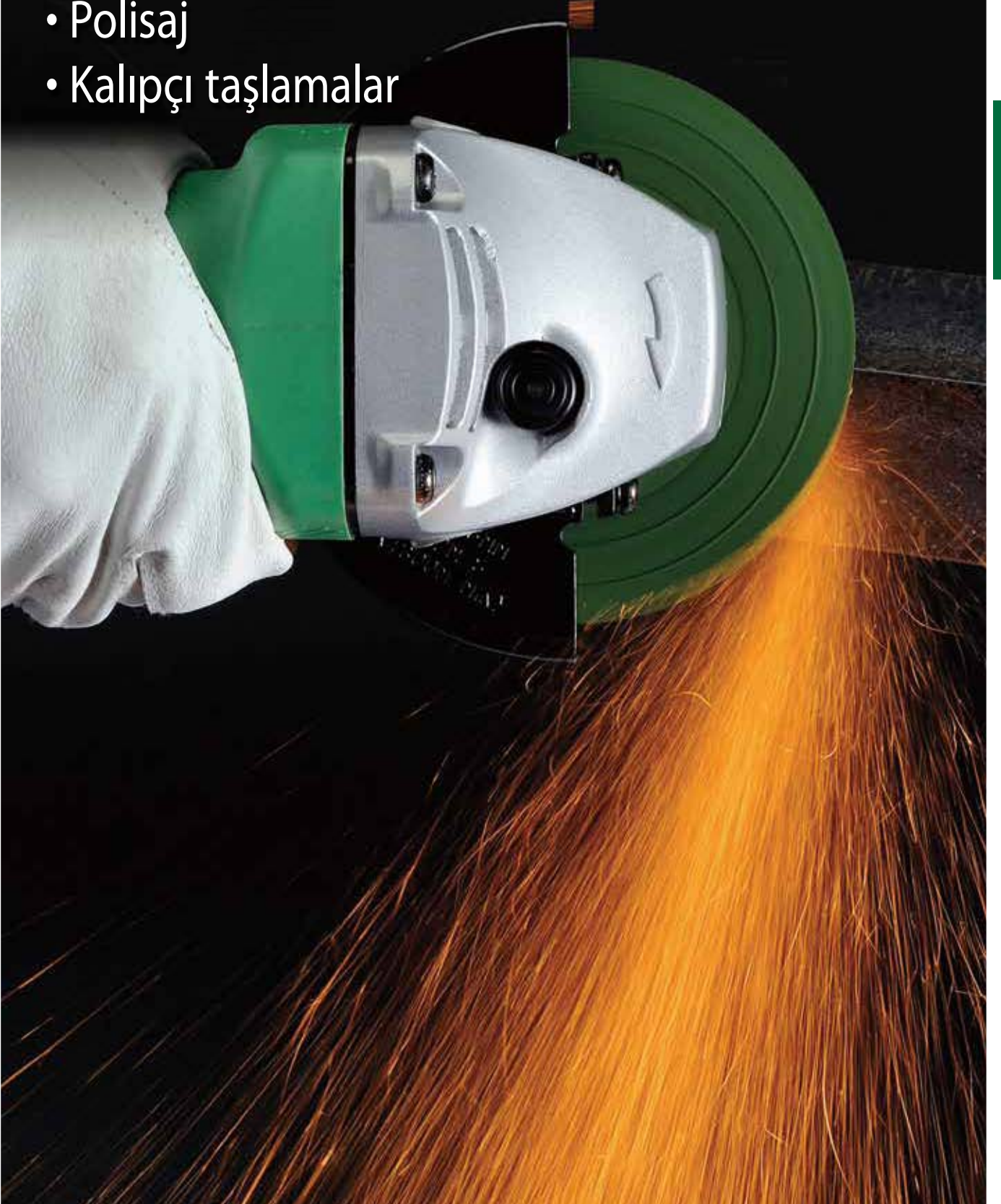

## G 12SW

115 mm - 1200 W Avuç Taşlama

**Kendi sınıfının  
en düşük gövde çapı!**



MODEL	G 12SW
Güç	1200 W
Disk çapı	115 mm
Mil vidası	M14x2
Devir sayısı	12000 dev/dk
Uzunluk	277 mm
Yükseklik	66 mm
Ağırlık	2.3 kg

**135\$**

Standart aksesuarlar:  
1 Anahtar, 1 Siperlik, 1 Yan tutamak

## AVUÇ TAŞLAMALAR

**G 12STA** 115 mm / 600 W Avuç Taşlama

- 600W'lık sağlam Hitachi motoru
- Tek elle kavranabilen ince gövde çapı
- Yavaş başlangıç özelliği ile ilk çalışma anında devir kademeli olarak artarak, daha uzun motor ömrü sunar
- "0" Voltaj koruması sayesinde makine fişe takılıyken enerji kesilmesi ve tekrar gelmesi durumunda motor doğrudan çalışmayarak olası iş kazalarının önüne geçilmiş olur.



MODEL	G 12STA
Güç	600 W
Disk çapı	115 mm
Mil vidası	M14x2
Devir sayısı	11500 dev/dk
Ağırlık	1.8 kg

59-Ş

Standart aksesuarlar:  
1 Anahtar, 1 Siperlik, 1 Yan tutamak

**G 12SR4** 115 mm / 730 W Avuç Taşlama

- 730 W'lık sağlam Hitachi motoru
- Motorun daha verimli ve uzun ömürlü çalışması için yeni tasarlanmış geniş fan ve optimize edilmiş hava akışı
- Tek elle daha iyi kavranabilmek için ince gövde çapı
- Yandan kontrol edilen açma kapama düğmesi



MODEL	G 12SR4
Güç	730 W
Disk çapı	115 mm
Mil vidası	M14x2
Devir sayısı	10000 dev/dk
Ağırlık	1.8 kg

75-Ş

Standart aksesuarlar:  
1 Anahtar, 1 Siperlik, 1 Yan tutamak

**G 12SN** 115 mm / 840 W Avuç Taşlama

- Aşırı yüklenmelere karşı yüksek dayanım
- 840 W'lık güçlü motor
- Ergonomik tasarım



MODEL	G 12SN
Güç	840 W
Disk çapı	115 mm
Mil vidası	M14x2
Devir sayısı	10000 dev/dk
Ağırlık	1.6 kg

93-Ş

Standart aksesuarlar:  
1 Anahtar, 1 Siperlik, 1 Yan tutamak

## AVUÇ TAŞLAMALAR

### G 12SQ 115 mm / 840 W Avuç Taşlama



- 840 W'lık güçlü Hitachi motoru
- Alttan tetik
- Ergonomik tasarım



MODEL	G 12SQ
Güç	840 W
Disk çapı	115 mm
Mil vidası	M14x2
Devir sayısı	10000 dev/dk
Ağırlık	1.6 kg

105-Ş

Standart aksesuarlar:

1 Anahtar, 1 Siperlik, 1 Yan tutamak

### G 12SW 115 mm / 1200 W Avuç Taşlama



- Ağır çalışma şartlarına uygun mükemmel tasarım
- 1200 W'lık yüksek performanslı motor
- Sınıfının en düşük gövde çapı



MODEL	G 12SW
Güç	1200 W
Disk çapı	115 mm
Mil vidası	M14x2
Devir sayısı	12000 dev/dk
Ağırlık	2.3 kg

135-Ş

Standart aksesuarlar:

1 Anahtar, 1 Siperlik, 1 Yan tutamak

### G 12SE2 115 mm / 1200 W Avuç Taşlama



- Ağır hizmet için geliştirilmiş güçlü motor
- Aşırı yüklenmelerde devamlı yüksek performans
- Kullanımı rahat büyük tetik
- Anahtarsız siperlik değiştirme



MODEL	G 12SE2
Güç	1200 W
Disk çapı	115 mm
Mil vidası	M14x2
Devir sayısı	11000 dev/dk
Ağırlık	2.1 kg

165-Ş

Standart aksesuarlar:

1 Anahtar, 1 Siperlik, 1 Yan tutamak

## AVUÇ TAŞLAMALAR

**G 13SN** 125 mm / 840 W Avuç Taşlama

- Aşırı yüklenmelere karşı yüksek dayanım
- 840W'lık güçlü motor
- Ergonomik tasarımı



MODEL	G 13SN
Güç	840 W
Disk çapı	125 mm
Mil vidası	M14x2
Devir sayısı	10000 dev/dk
Ağırlık	1.6 kg



93-Ş

Standart aksesuarlar:  
1 Anahtar, 1 Siperlik, 1 Yan tutamak

**G 13SB3** 125 mm / 1300 W Avuç Taşlama

- Güçlü 1300 W motor
- Ergonomik yapı
- 125 mm siperlik
- Hafif ve kompakt
- Isınmalara karşı dayanımlı



MODEL	G 13SB3
Güç	1300 W
Disk çapı	125 mm
Mil vidası	M14x2
Devir sayısı	11000 dev/dk
Ağırlık	1.9 kg



160-Ş

Standart aksesuarlar:  
1 Anahtar, 1 Siperlik, 1 Yan tutamak



## ELEKTRONİK AVUÇ TAŞLAMA - BÜYÜK TAŞLAMALAR

### G 13VA 125 mm / 1500 W Elektronik Avuç Taşlama



- 1500 W Güçlü motor
- Ayarlanabilen devir hızı
- Elektronik kontrol sistemi
- Değişken hız, sabit güç
- Yumuşak kalkış



MODEL	G 13VA
Güç	1500 W
Disk çapı	125 mm
Mil vidası	M14x2
Devir sayısı	2800-10500 dev/dk
Ağırlık	2.0 kg



265-Ş

Standart aksesuarlar:

1 Anahtar, 1 Siperlik, 1 Yan tutamak

### G 18ST 180 mm / 2200 W Büyük Taşlama



- Güçlü 2200 W Hitachi motoru
- Toz ve yabancı cisim girişinden minimum etkilenen labirent motor yapısı
- Daha çabuk soğumayı sağlayıp motor ömrünü uzatan iki parçalı stator
- Hitachi gücünü yansıtan agresif tasarım

MODEL	G 18ST
Güç	2200 W
Disk çapı	180 mm
Mil vidası	M14x2
Devir sayısı	8500 dev/dk
Ağırlık	4.9 kg



140-Ş

Standart aksesuarlar:

1 Anahtar, 1 Siperlik, 1 Yan tutamak

### G 18MR 180 mm / 2400 W Büyük Taşlama



- Alüminyum gövde
- Aşırı yüke dayanıklı 2400W Hitachi motoru
- Anahtarsız siperlik değiştirme
- Titreşim emici kol

MODEL	G 18MR
Güç	2400 W
Disk çapı	180 mm
Mil vidası	M14x2
Devir sayısı	8500 dev/dk
Ağırlık	5.4 kg



220-Ş

Standart aksesuarlar:

1 Anahtar, 1 Siperlik, 1 Yan tutamak



## BÜYÜK TAŞLAMALAR - POLİSAJ

**G 23ST** 230 mm / 2200 W Büyük Taşlama

- Güçlü 2200 W Hitachi motoru
- Toz ve yabancı cisim girişinden minimum etkilenen labirent motor yapısı
- Daha çabuk soğumayı sağlayıp motor ömrünü uzatan iki parçalı stator
- Hitachi gücünü yansıtan agresif tasarım



MODEL	G 23ST
Güç	2200 W
Disk çapı	230 mm
Mil vidası	M14x2
Devir sayısı	6600 dev/dk
Ağırlık	4.9 kg

150-Ş

Standart aksesuarlar:  
1 Anahtar, 1 Siperlik, 1 Yan tutamak

**G 23SE2** 230 mm / 2500 W Büyük Taşlama

- Güçlü 2500 W Hitachi motoru
- Aşırı yüklenmeye karşı mükemmel dayanım
- Ömür servis ömrü 170 saat
- Anahtar kullanmaksızın ayarlanabilen yeni siperlik



MODEL	G 23SE2
Güç	2500 W
Disk çapı	230 mm
Mil vidası	M14x2
Devir sayısı	6600 dev/dk
Ağırlık	5.0 kg

245-Ş

Standart aksesuarlar:  
1 Siperlik, 1 Yan tutamak, 1 Anahtar

**SP 18VA** 180 mm / 1250 W Polisaaj

- Güçlü 1250 W motor
- Sabit hız kontrolü ile daha verimli çalışma
- Yumuşak başlangıç ve aşırı yüklenmeye karşı koruma
- Hem tetikten hem de devir ayar düğmesinden hız değiştirme
- Kompakt ve hafif yapı



MODEL	SP 18VA
Güç	1250 W
Disk çapı	180 mm
Mil vidası	M14x2
Devir sayısı	0-3400 dev/dk
Ağırlık	2.8 kg

265-Ş

Standart aksesuarlar:  
1 Anahtar, 1 Kumlama disk, 1 Bone, 1 Lastik disk

## KALIPÇI TAŞLAMALAR

### GP 2S2 6 mm / 520 W Kalıpçı Taşlama



- Sınıfında en yüksek taşlama hızı 29 000 dev/dk.
- Kompakt ve ergonomik yeni tasarım
- Tamamı rulmanlı yapı
- Alüminyum alaşımlı dayanıklı ön gövde



MODEL	GP 2S2
Güç	520 W
Max. taş çapı	25 mm
Pens	6 mm
Devir sayısı	29000 dev/dk
Uzunluk	359 mm
Ağırlık	1.7 kg

255-\$

Standart aksesuarlar:  
1 Tutamak, 2 Anahtar

### GP 3V 6 mm / 760 W Kalıpçı Taşlama, Devir Ayarlı



- 7000-29000 dev/dk arasında ayarlanabilir devir
- Elektronik kontrol: yavaş başlangıç ve sabit devir
- Maksimum taş çapı: 25 mm



MODEL	GP 3V
Güç	760 W
Maxsimum taş çapı	25 mm
Pens	6 mm
Devir sayısı	7000-29000 dev/dk
Uzunluk	406 mm
Ağırlık	1.8 kg

320-\$

Standart aksesuarlar:  
1 Tutamak, 2 Anahtar



**KALE...**

- Delici
- Kırıcı deliciler
- Kırıcılar
- Beton kesme

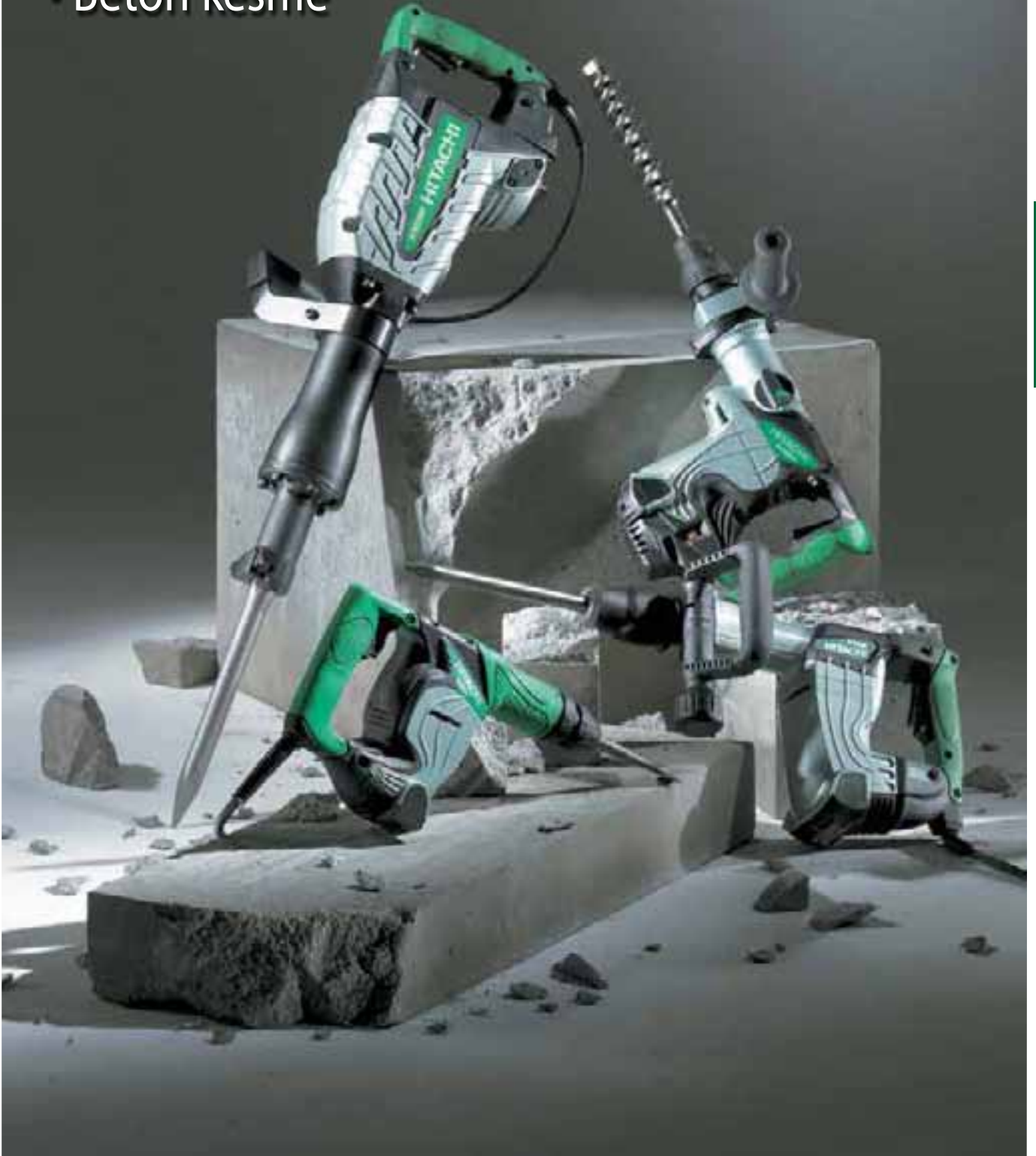

# Profesyonellerin tercihi

**DH 26PC** KIRICI  
DELİCİ

26 mm / 830 W



Kendi sınıfının  
en yüksek  
darbe kuvveti!



4

MODEL	DH 26PC	
Kapasite	Beton	3.4-26 mm
	Çelik	13 mm
	Ahşap	32 mm
Güç	830 W	
Darbe kuvveti	3.2 Joule	
Devir sayısı	0-1100/dk	
Darbe sayısı	0-4300/dk	
Uç tipi	SDS-Plus	
Ağırlık	2.8 kg	

Standart aksesuarlar:  
1 Çanta, 1 Tutamak, 1 Derinlik Mastarı

**195\$**

## DELİCİ - KIRICI DELİCİLER

### DH 26PB 26 mm / 830 W Delici



- 2 mod (delme - darbeli delme)
- Sınıfındaki en yüksek delme hızı
- Yüksek dayanım
- 830 W güçlü Hitachi motoru
- 3.2 joule darbe kuvveti
- Tek hamlede uç takma sistemi
- 360 derece dönebilen çift katmanlı tutamak



MODEL	DH 26PB	
Kapasite	Beton	3.4-26 mm
	Çelik	13 mm
	Ahşap	32 mm
Güç	830 W	
Darbe kuvveti	3.2 Joule	
Devir sayısı	0-1100/dk	
Darbe sayısı	0-4300/dk	
Uç tipi	SDS-Plus	
Ağırlık	2.8 kg	



175-<sup>-\$</sup>

Standart aksesuarlar:

1 Çanta, 1 Tutamak, 1 Derinlik Mastarı

### DH 24PH 24 mm / 730 W Kırıcı Delici



- Delme, darbeli delme ve kırıcı fonksiyonu
- Yüksek dayanım
- Ergonomik tasarım
- 2,7 Joule yüksek darbe kuvveti
- SDS Plus uyumlu uç sistemi



MODEL	DH 24PH	
Kapasite	Beton	3.4-24 mm
	Çelik	13 mm
	Ahşap	32 mm
Güç	730 W	
Darbe kuvveti	2.7 Joule	
Devir sayısı	0-1050/dk	
Darbe sayısı	0-3950/dk	
Uç tipi	SDS-Plus	
Ağırlık	2.7 kg	



180-<sup>-\$</sup>

Standart aksesuarlar:

1 Çanta, 1 Tutamak, 1 Derinlik Mastarı

### DH 26PC 26 mm / 830 W Kırıcı Delici



- 3 mod (delme - darbeli delme - kırıcı)
- Sınıfındaki en yüksek delme hızı
- Yüksek dayanım
- 830 W güçlü Hitachi motoru
- 3.2 joule darbe kuvveti
- Tek hamlede uç takma sistemi
- 360 derece dönebilen çift katmanlı tutamak



MODEL	DH 26PC	
Kapasite	Beton	3.4-26 mm
	Çelik	13 mm
	Ahşap	32 mm
Güç	830 W	
Darbe kuvveti	3.2 Joule	
Devir sayısı	0-1100/dk	
Darbe sayısı	0-4300/dk	
Uç tipi	SDS-Plus	
Ağırlık	2.8 kg	



195-<sup>-\$</sup>

Standart aksesuarlar:

1 Çanta, 1 Tutamak, 1 Derinlik Mastarı

## KIRICI DELİCİLER

**DH 28PCY** 28 mm / 850 W Kırıcı Delici

- 3 mod (delme - darbeli delme - kırıcı)
- Hitachi titreşim azaltma teknolojisi (UVP) ile %33 daha az titreşim
- Sınıfındaki en yüksek delme hızı
- Yüksek dayanım
- 850 W güçlü Hitachi motoru
- 3.4 joule darbe kuvveti
- Tek hamlede uç takma sistemi
- 360 derece dönebilen çift katmanlı tutamak



MODEL	DH 28PCY	
	Beton	3,4-28 mm
Kapasite	Çelik	13 mm
	Ahşap	32 mm
Güç	850 W	
Darbe kuvveti	3.4 Joule	
Devir sayısı	0-1100/dk	
Darbe sayısı	0-4300/dk	
Uç tipi	SDS-Plus	
Ağırlık	2.9 kg	



250-Ş

Standart aksesuarlar:  
1 Çanta, 1 Tutamak, 1 Derinlik Mastarı

**DH 40MC** 40 mm / 1000 W Kırıcı Delici

- Güçlü motor, 1000 W
- Sınıfındaki en hızlı delici
- Delme modunda emniyet debriyajı
- Düşük titreşim ve sessiz çalışma
- Değişken kilit mekanizmalı SDS-Max uç sistemi.



MODEL	DH 40MC	
Kapasite	Max. delme çapı	40 mm
	Max. karot çapı	105 mm
Güç	1000 W	
Darbe kuvveti	10.5 Joule	
Devir sayısı	0-620/dk	
Darbe sayısı	0-2800/dk	
Uç tipi	SDS-Max	
Ağırlık	7.1 kg	



530-Ş

Standart aksesuarlar:  
1 Çanta, 1 Tutamak



**KALE...**

**Sınıfının  
En Yüksek  
Kırma ve Delme  
Performansı**

**DH 52ME**

**BRUSH  
LESS  
MOTOR**

**Sınıfında tek  
kömürsüz  
AC motor**

**%20'ye  
varan  
Daha Hızlı  
Delme Performansı**

Delme Performansı (dev/dk)  
**2400** dev/dk

**%30'a  
varan  
Daha Yüksek  
Kırma Kapasitesi**

Kırma Gücü  
**22J**

4



## KIRICI DELİCİLER

**DH 45ME** 45 mm /1500 W Kırıcı Delici

- Sınıfının tek kömürsüz modeli!
- Kömür değiştirmeye son, daha az tamir bakım masrafı
- Sağlam alüminyum gövde (AHB)
- Elektronik devir ayarı
- Sürekli çalışma modu
- Jeneratörle kullanımda minimum performans düşüşü



MODEL	DH 45ME	
Kapasite	Max. delme çapı	45 mm
	Max. karot çapı	125 mm
Güç	1500 W	
Darbe kuvveti	13.4 Joule	
Devir sayısı	0-120/310/dk	
Darbe sayısı	0-1200/2950/dk	
Uç tipi	SDS-Max	
Ağırlık	9 kg	



900-Ş

Standart aksesuarlar:  
1 Çanta, 1 Tutamak, 1 Derinlik Mastarı

**DH 52ME** 52 mm / 1500W Kırıcı Delici

- Sınıfının tek kömürsüz motorlu modeli!
- Kömürsüz motor ile kömür değişimine son! Daha az tamir bakım masrafı.
- Kömürsüz motoru sayesinde voltaj düşüşlerinde performans kaybı yaşamaz!
- Jeneratör ile çalışmaya uygun
- Yüksek dayanımlı alüminyum gövde ile daha sağlam
- Elektronik devir ayarı
- Geniş ve ergonomik tetik
- Sürekli çalışma modu



MODEL	DH 52ME	
Kapasite	Max. delme çapı	52 mm
	Max. karot çapı	160 mm
Güç	1500 W	
Darbe kuvveti	22 Joule	
Devir sayısı	110-280/dk	
Darbe sayısı	1000-2400/dk	
Uç tipi	SDS-Max	
Ağırlık	11.0 kg	



1.020-Ş

Standart aksesuarlar:  
1 Çanta, 1 Tutamak, 1 Derinlik mastarı



## KIRICILAR

### H 41MB 5 kg / 930 W Kırıcı



- Yüksek kırma performansı; 10 Joule
- Fonksiyonel ve sağlam tasarım
- Otomatik yağlama sistemi
- Auto-stop (sigortalı) tip kömür
- SDS-Max uç sistemi



MODEL	H 41MB
Güç	930 W
Darbe sayısı	3000/dk
Darbe kuvveti	10 Joule
Uzunluk	430 mm
Uç tipi	SDS-Max
Ağırlık	5.1 kg



550-<sup>-\$</sup>

Standart aksesuarlar:

1 Çanta, 1 Tutamak, 1 adet Murç

### H 45ME 7 kg /1150 W Kırıcı



- Şebeke elektrik gerilimi düşünce performans hızını korur.
- Jeneratör ile uyumlu
- Titreşim emici tutamak



MODEL	H 45ME
Güç	1150 W
Darbe sayısı	1430-2850/dk
Darbe kuvveti	13.6 Joule
Uzunluk	480 mm
Uç tipi	SDS-Max
Ağırlık	7 kg



830-<sup>-\$</sup>

Standart aksesuarlar:

1 Çanta, 1 Tutamak, 1 Derinlik Mastarı

### H 60MC 10 kg / 1250 W Kırıcı



- Yüksek kırma performansı; 22 Joule
- Fonksiyonel ve sağlam tasarım
- Titreşim emici tutamak
- SDS-Max uç sistemi



MODEL	H 60MC
Güç	1250 W
Darbe sayısı	1600/dk
Darbe kuvveti	22 Joule
Uzunluk	570 mm
Uç tipi	SDS - Max
Ağırlık	10.2 kg



720-<sup>-\$</sup>

Standart aksesuarlar:

1 Çanta, 1 Tutamak, 1 adet Murç

## KIRICILAR

**H 60ME** 11 kg / 1500 W Kırıcı

- Yüksek kırma performansı
- Kömürsüz Motor teknolojisi sayesinde uzatma kablosuyla bile güç kaybına son
- Titreşim engelleyici tutamak
- SDS-Max uç sistemi

**BRUSH  
LESS  
MOTOR**

MODEL	H 60ME
Güç	1500 W
Darbe sayısı	1500-2100/dk
Darbe kuvveti	26.5 Joule
Uzunluk	585 mm
Uç tipi	SDS - Max
Ağırlık	11.6 kg

**890-\$**

Standart aksesuarlar:  
1 Çanta, 1 Tutamak, 1 adet Murç

**H 65SB3** 18 kg / 1340 W Kırıcı

- Kullanıcıyı yüksek titreşimden koruyan UVP özelliği
- Sınıfındaki en yüksek kırma gücü
- Doğal kauçuktan yapılmış 360° dönebilen yan tutamak
- Yumuşak, kaymayan ve kullanımı kolaylaştıran titreşim emici sap
- Dayanıklı ve sağlam alüminyum gövde
- 30 mm altıgen uç sistemi
- Minimum 2.5 KW jeneratör ile Kullanılabilir

**UVP  
USER VIBRATION PROTECTION**

MODEL	H 65SB3
Güç	1340 W
Darbe sayısı	1400/dk
Darbe kuvveti	45 Joule
Uzunluk	731 mm
Uç tipi	30 mm Altıgen
Ağırlık	18.0 kg

**1.260-\$**

Standart aksesuarlar  
Tutamak, 1 adet Murç, 1 Çanta



## KIRICILAR - BETON KESME

### H 70SA 20 kg / 1240 W Kırıcı



- 20 kg sınıfında tek dik kırıcı
- Kullanıcıyı yormayan
  - kompakt yapı
  - çok emici T-tip sap
- Motora yabancı maddelerin girmesini engelleyen toz tutucu sistem
- Düşük titreşim ve sessiz çalışma
- Auto-stop (sigortalı) tip kömür
- 30 mm altıgen uç sistemi
- Minimum 2.5 KW jeneratör ile kullanılabilir



MODEL	H 70SA
Güç	1240 W
Darbe sayısı	1400/dk
Darbe kuvveti	45 Joule
Uzunluk	625 mm
Uç tipi	30 mm Altıgen
Ağırlık	18.0 kg



1.400-Ş

Standart aksesuarlar  
1 adet Murç

### H 90SG 32 kg / 2000 W Kırıcı



- Kendi sınıfının en yüksek darbe kuvveti
- UVP teknolojisi sayesinde %54'e varan düşük titreşim
- Rahat kullanım için geliştirilmiş ergonomik sap tasarımı
- 28.5 mm Altıgen uç



MODEL	H 90SG
Güç	2000 W
Darbe sayısı	1000/dk
Darbe kuvveti	70 Joule
Uzunluk	860 mm
Uç tipi	28.5 mm Altıgen
Ağırlık	32.0 kg



1.950-Ş

### CM 12Y 100 mm / 2400 W Beton Kesme



- Yumuşak kalkışlı 2400 W motor
- Mükemmel dengeli yapı
- Maksimum kesme derinliği 100 mm
- Benzinli tiplere göre kolay bakım
- Düşük titreşim ve gürültüsüz çalışma



MODEL	CM 12Y
Güç	2400 W
Bıçak çapı	305 mm
Kesme derinliği	100 mm
Tek kesim derinliği	50 mm
Devir sayısı	5000/dak
Ağırlık	11.5 kg

\* Testere ürüne dahil değildir

1.350-Ş

Standart aksesuarlar  
1 Anahtar

**KALE...**

- Daire testereler
- Profil kesme
- Gönye kesme
- Raylı gönye kesmeler



## DAİRE TESTERELER

### C 7MFA 190 mm / 1010 W Daire Testere



- 190 mm bıçak çapı, 68 mm kesme derinliği
- Paralel ayarlama sistemi
- Güçlü alüminyum taban
- Yüksek performanslı tungsten karbid uçlu 40 diş bıçak
- Ayarlanabilir kesme derinliği ve kesme açısı

MODEL	C 7MFA
Güç	1010 W
Devir sayısı	5500/dk
Testere çapı	190 mm
Testere göbek çapı	30 mm
Maksimum kesme derinliği 90°	68 mm
Maksimum kesme derinliği 45°	46 mm
Ağırlık	3.6 kg



130-Ş

Standart aksesuarlar  
1 Bıçak, 1 Anahtar, 1 Kılavuz

### C 9U3 235 mm / 2000 W Daire Testere



- Magnezyum alaşımlı gövde sayesinde sınıfındaki en hafif makina; 6,8 kg.
- Maksimum kesme derinliği 86 mm
- Ayarlanabilir kesme derinliği ve kesme açısı
- Toz toplama aparatı ile temiz ve rahat çalışma
- Yumuşak sap ve büyük tetik
- Aşınmaya dayanıklı, uzun ömürlü nikel kaplamalı alüminyum taban
- Tamamı rulmanlı yapı
- Mil kilitli



MODEL	C 9U3
Güç	2000 W
Devir sayısı	5200/dk
Testere çapı	235 mm
Testere göbek çapı	30 mm
Maksimum kesme derinliği 90°	86 mm
Maksimum kesme derinliği 45°	65 mm
Ağırlık	7.2 kg



260-Ş

Standart aksesuarlar  
1 Bıçak, 1 Allen anahtar, 1 Kılavuz, 1 Toz toplama aparatı,



## PROFİL KESME - GÖNYE KESME

**CC 14ST** 355 mm / 2200 W Profil Kesme

- 2200 W güçlü motor
- Hızlı kilitleme mekanizması
- Kıvılcım koruyucu
- Mil kilitli



MODEL	CC 14ST
Güç	2200 W
Devir sayısı	3800/dk
Karbon taş çapı	355 mm
Karbon taş göbek çapı	25,4 mm
Kapasite	Boru Ø 130 mm Profil 95x200 mm
Ağırlık	17 kg

**230-Ş**

Standart aksesuarlar  
1 Kesme Taşı, 1 Anahtar

**C 10FCE2** 255 mm / 1520 W Gönye Kesme

- 1520 W güçlü Hitachi motoru
- 48° sola yatar kafa
- 0°-52° sağ/sol döner tabla
- 0°-15°, 22.5°, 31.6° ve 45°'lerde otomatik sabitleme
- Kesilecek malzemenin daha sabit tutulması için genişletilmiş tabla yüzeyi
- Kolay bıçak değişimi için mil kilit mekanizması
- Temiz çalışma için toz torbası



MODEL	C 10FCE2
Güç	1520 W
Devir sayısı	5000/dk
Testere çapı	255 mm
Testere göbek çapı	30 mm
Maksimum kesme derinliği 90°	89x101 mm
Maksimum kesme derinliği 45°	59x102 mm
Ağırlık	11.9 kg

**370-Ş**

Standart aksesuarlar  
1 Bıçak, 1Toz torbası, 1 Anahtar takımı



## RAYLI GÖNYE KESMELER

### C 8FSE 216 mm / 1050 W Raylı Gönye Kesme



- Çok amaçlı gönye kesme
- 305 mm kesme genişliği
- 45° sola raylı yatar kafa
- 0°- 5°- 22.5°- 30° ve 45°'li sağ/sol kesim
- Döner tablalı, dayanıklı dökme alt taban
- Toz tutma torbası ile birlikte



MODEL	C 8FSE
Güç	1050 W
Devir sayısı	5500/dk
Testere çapı	216 mm
Testere göbek çapı	30 mm
Maksimum kesme derinliği 0°	65x312 mm
Maksimum kesme derinliği 45°	65x220 mm
Ağırlık	14 kg



555-₺

Standart aksesuarlar

1 Bıçak, 1 Toz torbası, 1 Anahtar takımı

### C 12RSH2 305 mm / 1520 W Raylı Gönye Kesme - Lazerli Kesim Çizgisi



- 630 mm genişliğinde, alüminyum alaşımlı tabla
- Kusursuz ve hızlı kesim için kılavuz lazer ışık
- Her iki yöne 45° ye kadar yatabilen bıçak
- Her iki yöne 57° ye kadar dönebilen alt tabla
- Sessiz çalışan kayış aktarmalı motor



MODEL	C 12RSH2
Güç	1520 W
Devir sayısı	4000/dk
Testere çapı	305 mm
Testere göbek çapı	30 mm
Maksimum kesme derinliği 0°	105x312 mm
Maksimum kesme derinliği 45°	68x312 mm
Ağırlık	27 kg



850-₺

Standart aksesuarlar

1 Bıçak, 1 Toz torbası, 1 Anahtar takımı





**KALE...**

- Planyalar
- Tank zımparalar
- Titreşimli zımparalar
- Eksantrik zımpara
- Frezeler



## PLANYALAR

### P 20ST 82 mm / 580 W Planya



- 580 W motor gücü
- Lamba ölçüsü 9 mm
- Kolay ayarlanabilen kesme derinlik ayarı
- Sadece 2.5 kg



126-\$

#### Planya bıçakları

ÜRÜN KODU	AÇIKLAMA/ÖLÇÜ	FİYAT
750470	Jilet bıçak, 82 mm P 20ST (2 adet)	5,00-€

#### MODEL P 20ST

Güç	580 W
Kesme genişliği	82 mm
Kesme derinliği	1.5 mm
Devir sayısı	17000/dk
Ağırlık	2.5 kg

Standart aksesuarlar

1 Bıçak, 1 Bıçak Yerleştirme Mastarı, 1 Kılavuz, 1 Anahtar

### P 20SA2 82 mm / 720 W Planya



- Hızlı kesim için güçlü motor 720 W
- Pürüzsüz yüzey için alüminyum alaşım taban
- Lamba ölçüsü 25 mm
- Kolay kullanım için D-Tip sap



380-\$

#### Planya bıçakları

ÜRÜN KODU	AÇIKLAMA/ÖLÇÜ	FİYAT
750470	Jilet bıçak, 82 mm P 20SA2 (2 adet)	5,00-€

#### MODEL P 20SA2

Güç	720 W
Kesme genişliği	82 mm
Kesme derinliği	3 mm
Devir sayısı	14000/dk
Ağırlık	3.0 kg

Standart aksesuarlar

1 Bıçak, 1 Bıçak Yerleştirme Mastarı, 1 Kılavuz, 1 Anahtar

6



## TANK ZIMPARALAR

**SB 10S2** 100x610 mm / 1020 W Tank Zımpara

- 1020 W elektronik devir ayarlı motor
- Makine çalışırken bandı ve zımparalama işlemini kontrol edebileceğiniz gövde üzerinde şeffaf pencere
- Köşe noktalarda verimli çalışma için sol tarafa yerleştirilmiş toz toplama torbası
- Bant ölçüsü 100 x 610 mm



MODEL	SB 10S2
Güç	1020 W
Bant ölçüsü	100x610 mm
Bant hızı	420 m/dk
Ağırlık	5.2 kg

**300-\$**

Standart aksesuarlar  
1 Bant zımpara, 1 Toz torbası

**SB 10V2** 100x610 mm / 1020 W Tank Zımpara - Devir Ayarlı

- 1020 W elektronik devir ayarlı motor
- Makine çalışırken bandı ve zımparalama işlemini kontrol edebileceğiniz gövde üzerinde şeffaf pencere
- Köşe noktalarda verimli çalışma için sol tarafa yerleştirilmiş toz toplama torbası



MODEL	SB 10V2
Güç	1020 W
Bant ölçüsü	100x610 mm
Bant hızı	240-420 m/dk
Ağırlık	5.2 kg

**325-\$**

Standart aksesuarlar  
1 Bant zımpara, 1 Toz torbası



## TİTREŞİMLİ ZIMPARALAR

### SV 12SH 110x190 mm / 200 W Titreşimli Zımpara



- 200 W motor gücü
- Toz emme özelliği
- Rahat kullanım ve kontrol
- Üçgen ped yapısıyla köşelerde bile mükemmel sonuç



MODEL	SV 12SH
Güç	200 W
Devir sayısı	14000/dk
Zımpara ölçüsü	Dikdörtgen Zımpara 110 x 190 mm
Zımpara ölçüsü	Üçgen Zımpara 96 x 96 x 96 mm
Titreşim çapı	1.5 mm
Ağırlık	1.0 kg

116-\$

Standart aksesuarlar  
1 Zımpara kağıt, 1 Toz torbası

### SV 12SG 110x100 mm / 200 W Titreşimli Zımpara



- Güçlü motor 200 W
- Sınıfındaki en yüksek zımparalama ve toz toplama kapasitesi
- Yeni ergonomik tasarım
  - Kullanım kolaylığı
  - Avuca rahat oturan gövde
- Tamamı rulmanlı yapı



MODEL	SV 12SG
Güç	200 W
Devir sayısı	14000/dk
Zımpara ölçüsü	110x100 mm
Titreşim çapı	1.5 mm
Ağırlık	1.1 kg



95-\$

Standart aksesuarlar  
1 Zımpara kağıt, 1 Toz torbası

### FSV 10SA 94x184 mm / 180 W Titreşimli Zımpara



- 200W Güçlü motor
- Sınıfındaki en yüksek zımparalama ve toz toplama kapasitesi
- Yeni ergonomik tasarım
- Avuca rahat oturan gövde



MODEL	FSV 10SA
Güç	180 W
Devir sayısı	10000-20000/dk
Zımpara ölçüsü	94x184 mm
Titreşim çapı	2 mm
Ağırlık	1.0 kg



90-\$

Standart aksesuarlar  
1 Zımpara tablası, 1 Toz torbası

## TİTREŞİMLİ ZIMPARA - EKSANTRİK ZIMPARA

**SV 12SD** 114x228 mm / 300 W Titreşimli Zımpara

- Mükemmel toz emme özelliği
- Düzgün yüzey ve minimum titreşimi sağlayan sürücülü sistem
- Hızlı ve kolay zımpara değiştirme için mandallı sistem
- Tamamı rulmanlı yapı

MODEL	SV 12SD
Güç	300 W
Devir sayısı	10000/dk
Zımpara ölçüsü	114x228 mm
Titreşim çapı	2.4 mm
Ağırlık	2.8 kg

215-<sup>-\$</sup>

Standart aksesuarlar  
1 Zımpara kağıt, 1 Toz torbası

**SV 13YA** 125 mm / 230 W Eksantrik Zımpara

- Avuç içine rahat oturan ergonomik gövde sayesinde kolay kullanım
- Yüksek zımparalama performansı
- Yüksek toz toplama performansı
- Elektronik kontrol özelliği ile farklı devirlerde sabit hız kontrolü
- Rulmanlı yapı



MODEL	SV 13YA
Güç	230 W
Devir sayısı	7000-12000/dk
Kağıt ölçüsü	Ø 125 mm
Taban ölçüsü	Ø 125 mm
Titreşim çapı	3.2 mm
Ağırlık	1.4 kg

165-<sup>-\$</sup>

Standart aksesuarlar  
1 Zımpara kağıt, 1 Toz torbası



## FREZELER

### M 8V2 8 mm / 1150 W Freze



- Güçlü motor 1150 W
- Elektronik devir ayarlı sabit hız kontrolü ve yumuşak kalkış
- Kol üzerindeki devir ayar düğmesi ile rahat ve kolay kullanım
- Maksimum freze stroku 60 mm
- Hızlı ve kolay uç değiştirme
- Ölçekli skala üzerinden hassas kesme derinlik ayarı yapabilmek



MODEL	M 8V2
Güç	1150 W
Devir sayısı	11000-25000/dk
Pens çapı	8 mm
Freze stroku	60 mm
Ağırlık	3.6 kg



370-<sup>-\$</sup>

Standart aksesuarlar  
1 Düz kılavuz, 1 Şablon kılavuz, 1 Anahtar

### M 12VE 12 mm / 2000 W Freze



- Güçlü 2000 W motor
- Elektronik kontrollü devir ayarı
- Değişken açılı yan tutamak kolları
- Derinlik ayarı için hassas ve kullanımı kolay skala
- Yumuşak kalkış
- Alüminyum alaşımlı taban ve ara kapak
- Hafif, sadece 5.3 kg



MODEL	M 12VE
Güç	2000 W
Devir sayısı	8000-22000/dk
Pens çapı	12 mm
Freze stroku	65 mm
Ağırlık	5.3 kg



385-<sup>-\$</sup>

Standart aksesuarlar  
1 kılavuz, 1 Anahtar

6



**KALE...**

- Dekupajlar
- Sac kesme
- Tilki kuyruđu
- Üfleyiciler
- Sıcak hava tabancaları
- Elektrikli zincirli testere
- Yüksek basınçlı yıkamalar



## DEKUPAJLAR

### CJ 65V3 65 mm / 400 W Dekupaj



- Geliştirilmiş endüvi yapısı sayesinde daha uzun kullanım
- Güvenli ve rahat tutuş için yumuşak sap
- Elektronik hız kontrollü büyük tetik
- İstenildiğinde vakum yapabilen bir cihaza takılabilen toz toplama aparatı
- 45° sağ-sol açılı kesim
- Emniyet kapağı



MODEL		CJ 65V3
Güç		400 W
Kesme derinliği	Ahşap	65 mm
	Çelik	6 mm
Devir sayısı		0-3000/dk
Strok uzunluğu		18 mm
Ağırlık		1.5 kg



110-Ş

Standart aksesuarlar  
1 Bıçak, 1 Anahtar

### CJ 90VST 90 mm / 705 W Dekupaj



- Hassas kesimler için elektronik hız ayarı ünitesi
- Kolay ve rahat anahtarsız bıçak değiştirme
- 3 kademeli yörüngesel hareket.
- Sağlam ve hafif alüminyum alaşımli dişli kutusu
- 45° sağ-sol kesim imkânı
- Yumuşak ve kullanışlı tutamak



MODEL		CJ 90VST
Güç		705 W
Kesme derinliği	Ahşap	90 mm
	Çelik	8 mm
Min. kesme yarı çapı		25 mm
Devir sayısı		850-3000/dk
Strok uzunluğu		20 mm
Ağırlık		2.2 kg



150-Ş

Standart aksesuarlar  
1 Çanta, 1 Bıçak, 1 Anahtar

### CJ 110MV 110 mm / 720 W Dekupaj



- Güçlü 720 W motor
- Hassas kesim işleri için elektronik devir ayarı
- Kolay ve güvenilir anahtarsız uç değiştirme
- Dört pozisyonlu yörüngesel kesim
- Güçlü üfleme ve ışıklı aydınlatma fonksiyonu sayesinde kolay kesim çizgisi takibi
- 45° sağ-sol açılı kesim
- Yumuşak ve kullanışlı D tip sap



MODEL		CJ 110MV
Güç		720 W
Kesme derinliği	Ahşap	110 mm
	Çelik	10 mm
Min. kesme yarı çapı		25 mm
Devir sayısı		850-3000/dk
Strok uzunluğu		26 mm
Ağırlık		2.2 kg



220-Ş

Standart aksesuarlar  
1 Çanta, 1 Bıçak, 1 Toz toplama aparatı,



## DEKUPAJLAR - SAC KESME

**CJ 160V** 160 mm / 800 W Dekupaj

- 800 W güçlü motor.
- Hassas kesimler için elektronik hız ayarı
- Kolay ve güvenilir uç değiştirme
- Yumuşak ve kullanışlı D sap
- Düşük titreşim

MODEL	CJ 160V	
Güç	800 W	
Kesme derinliği	Ahşap	160 mm
	Çelik	10 mm
Min. kesme yarı çapı	25 mm	
Devir sayısı	0-800 / 2800/dk	
Strok uzunluğu	26 mm	
Ağırlık	2.5 kg	

**250-\$****CJ 160VA** 160 mm / 800 W Dekupaj

- 800 W güçlü motor.
- Hassas kesimler için elektronik hız ayarı
- Kolay ve güvenilir uç değiştirme
- Yumuşak ve kullanışlı mantar sap
- Düşük titreşim

MODEL	CJ 160VA	
Güç	800 W	
Kesme derinliği	Ahşap	160 mm
	Çelik	10 mm
Min. kesme yarı çapı	25 mm	
Devir sayısı	0-800 / 2800/dk	
Strok uzunluğu	26 mm	
Ağırlık	2.5 kg	

**250-\$****CE 16SA** 1.6 mm / 400 W Sac Kesme

- Hızlı kesim; 6.3 m/dk
- Kolay değiştirilebilir 8 kesme kenarlı bıçak
- Kopan parçalara karşı özel muhafaza
- Tek el kullanım için ideal boyutlar gövde çevresi; 184mm

MODEL	CE 16SA	
Güç	400 W	
Strok sayısı	Çelik	1.6 mm
	Paslanmaz	1.2 mm
	Alüminyum	2.3 mm
Uzunluk	250 mm	
Ağırlık	1.7 kg	

**490-\$**

Standart aksesuarlar  
1 Kalınlık kılavuzu, 1 Anahtar

## TILKI KUYRUĞU - ÜFLEYİCİLER

### CR 13V2 300 mm / 1010 W Tilki Kuyruğu



- Güçlü 1010 W motor
- Ergonomik tasarım ve sağlam gövde
- Düz kesim
- Anahtarsız testere takabilme özelliği
- Aşağı veya yukarı yönde kesim yapma imkanı sağlayan bıçak mekanizması

MODEL	CR 13V2
Güç	1010 W
Boru	130 mm
Kesme derinliği	Çelik 19 mm
	Ahşap 300 mm
Strok uzunluğu	29 mm
Strok sayısı	0-2800/dk
Ağırlık	3.3 kg

230-<sup>-\$</sup>

Standart aksesuarlar  
1 Çanta, 1 Bıçak, 1 Anahtar

### RB 40SA 3.8 m<sup>3</sup>/dk. / 550 W Üfleyici



- Sınıfında en yüksek hava hacmi 3.8 m<sup>3</sup>/dk
- Hem üfleyici hem de toz toplayıcı olarak kullanılabilir
- Yüzeyde el değmeden sabit olarak kullanılabilir



MODEL	RB 40SA
Hava akış hacmi	3.8 m <sup>3</sup> /dk
Hava basıncı	5.5 kPa
Devir sayısı	16000/dk
Güç	550 W
Ağırlık	1.7 kg

140-<sup>-\$</sup>

Standart aksesuarlar  
1 Toz torbası, 1 Ağızlık

### RB 40VA 3.8 m<sup>3</sup>/dk. / 550 W Üfleyici - Devir Ayarlı



- Değişken hız kontrollü tetik
- Sınıfında en yüksek hava hacmi 3.8 m<sup>3</sup>/dk.
- Hem üfleyici hem de toz toplayıcı olarak kullanılabilir
- Yüzeyde el değmeden sabit olarak kullanılabilir



MODEL	RB 40VA
Hava akış hacmi	0-3.8 m <sup>3</sup> /dk.
Hava basıncı	0-5.5 kPa
Devir sayısı	0-16000/dk
Güç	550 W
Ağırlık	1.7 kg

145-<sup>-\$</sup>

Standart aksesuarlar  
1 Toz torbası, 1 Ağızlık

## SICAK HAVA TABANCALARI - ELEKTRİKLİ ZİNCİRLİ TESTERE

**RH 600T** 600 °C / 2000 W Sıcak Hava Tabancası

- 450/600 °C çift ısı ayarı
- Hızlı soğutma
- Yüksek ısı koruması
- Rahat ve kontrollü kullanım için yumuşak sap
- Sabit noktada sürekli kullanım için askı kancası

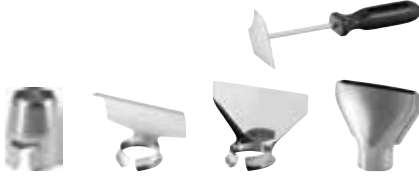

Standart aksesuarlar  
1 Çanta, 4 Nozul, 1 Raspa

**MODEL RH 600T**

Güç	2000 W
Sıcaklık kademeleri	450/600 °C
Fan hızı	250/500 litre/dk
Ağırlık	0.57 kg

**60-Ş****RH 650V** 650 °C / 2000 W Sıcak Hava Tabancası - Isı Ayarlı

- 2000 Watt
- Ayarlanabilen sıcaklık ve fan hızı
- LCD gösterge
- Sürekli kullanımda sabit ısı kontrolü ve aşırı ısınmayı önleyen sistem
- Rahat ve kontrollü kullanım için yumuşak sap

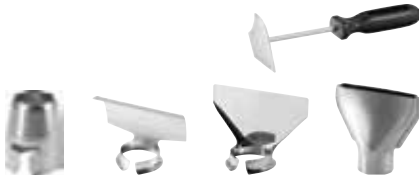

Standart aksesuarlar  
1 Çanta, 4 Nozul, 1 Raspa

**MODEL RH 650V**

Güç	2000 W
Sıcaklık kademeleri	50-650 °C
Fan hızı	250-500 litre/dk
Ağırlık	0.79 kg

**89-Ş****CS 40SB** 400 mm / 1900 W Elektrikli Zincirli Testere

- Aletsiz zincir sıkıştırma
- Zincir yağının akış miktarını ayarlama

**MODEL CS 40SB**

Güç	1900 W
Pala uzunluğu	400 mm
Zincir hızı	14.5 m/sn
Yağ tank kapasitesi	200 ml
Ağırlık	4.9 kg

**170-Ş**

Standart aksesuarlar  
1 Rehber çubuğu, 1 Zincir testere, 1 Zincir çanta

## YÜKSEK BASINÇLI YIKAMALAR

### AW 100 100 bar / 1400 W Yüksek Basınçlı Yıkama



- 1400W motor gücü
- Yüksek basınç hortumu; 5m uzunluk
- Dikey yapısı ile kolay taşınabilir ve depolama
- Rahat kullanımı sağlayan hafif ve kompakt yapı
- Motorun yanmasını engelleyen ısı koruma tertibatı

Standart aksesuarlar  
1 Tetikli Püskürtme Ucu , 5 m Hortum, 2 Nozul,  
1 Su Besleme Konnektörü, 1 Nozul Temizleyici,  
1 Kablo Tutucu, 1 Tutamak

MODEL	AW 100
Güç	1400 W
Maksimum basınç	100 bar
Çalışma basıncı	70 bar
Maksimum su sarfiyatı	330 litre/saat
Su sıcaklığı	40° C veya daha az
Boyut (U x G x D)	305 x 245 x 465 mm
Ağırlık	5.4 kg



155-₺

### AW 130 130 bar / 1600 W Yüksek Basınçlı Yıkama



- 1600W motor gücü
- 10 metre uzunluğundaki yüksek basınç hortumu sayesinde geniş alanda yıkama
- Dikey yapısı ile kolay taşınabilir ve depolama
- Rahat kullanımı sağlayan hafif ve kompakt yapı
- Motorun yanmasını engelleyen ısı koruma tertibatı
- Sifon fonksiyonlu

Standart aksesuarlar  
1 Tetikli Püskürtme Ucu , 10m Hortum, 2 Nozul,  
1 Su Besleme Konnektörü, 1 Nozul Temizleyici,  
1 Kablo Tutucu, 1 Tutamak

MODEL	AW 130
Güç	1600 W
Maksimum basınç	130 bar
Çalışma basıncı	90 bar
Maksimum su sarfiyatı	360 litre/saat
Su sıcaklığı	40° C veya daha az
Boyut (U x G x D)	325 x 260 x 790 mm
Ağırlık	8.3 kg



245-₺

### AW 150 150 bar / 2000 W Yüksek Basınçlı Yıkama



- 2000W motor gücü
- 10 metre uzunluğundaki yüksek basınç hortumu sayesinde geniş alanda yıkama
- Değişken ağız sayesinde basınç ayarı yapabilmek
- Makine üzerine monte edilmiş geniş hortum makarası
- Dikey yapısı ile kolay taşınabilir ve depolama
- Rahat kullanımı sağlayan hafif ve kompakt yapı
- Motorun yanmasını engelleyen ısı koruma tertibatı
- Sifon fonksiyonlu

Standart aksesuarlar  
1 Tetikli Püskürtme Ucu , 10m Hortum, 2 Nozul,  
1 Su Besleme Konnektörü, 1 Nozul Temizleyici,  
1 Kablo Tutucu, 1 Tutamak

MODEL	AW 150
Güç	2000 W
Maksimum basınç	150 bar
Çalışma basıncı	110 bar
Maksimum su sarfiyatı	400 litre/saat
Su sıcaklığı	40° C veya daha az
Boyut (U x G x D)	425 x 345 x 905 mm
Ağırlık	12.4 kg



450-₺

**KALE<sub>III</sub>**

- Aksesuarlar



## EKONOMİK SERİ SDS-PLUS DELİCİ UÇLARI

KOD NO	ÇAP (mm)	ÇALIŞMA UZUNLUĞU (mm)	TOPLAM UZUNLUK (mm)	FİYAT (USD)
401006	6	50	110	0,92
401007	6	100	160	1,00
401914	7	50	110	1,04
401915	7	100	160	1,05
401008	8	50	110	1,08
401009	8	100	160	1,09
401010	10	50	110	1,13
401011	10	100	160	1,22
401012	12	100	160	1,36
401339	12	150	210	1,63
401013	12	400	460	3,24
401014	14	100	160	1,89
401341	16	150	210	2,72
401017	16	400	460	5,11
401018	18	120	210	3,72
401019	18	220	310	4,28
401020	18	365	460	5,66
401021	20	130	210	4,92
401022	20	225	310	5,28
401023	20	365	460	6,96
401024	22	170	260	5,52
401025	22	365	460	8,74
401026	25	170	260	6,96
401342	25	295	350	8,17
401028	26	170	260	7,20
401029	26	365	460	10,84



## EKONOMİK SERİ SDS-PLUS UÇ SETLERİ

KOD NO	AÇIKLAMA	FİYAT (USD)
401979	5 Parça, Ekonomik Seri SDS-Plus uç seti 5 - 6 x 110 mm, 8 - 10 - 12 x 160 mm	5,24
401985	5 Parça, Ekonomik Seri SDS-Plus uç seti 6 - 8 - 10 - 12 - 14 x 160 mm	6,72











## EKONOMİK SERİ SDS-MAX DELİCİ UÇLARI

KOD NO	ÇAP (mm)	ÇALIŞMA UZUNLUĞU (mm)	TOPLAM UZUNLUK (mm)	FİYAT (USD)
401509	12	195	340	8,05
401510	12	395	540	11,50
401511	14	195	340	9,20
401512	14	395	540	12,42
401515	16	195	340	10,12
401516	16	395	540	13,11
401517	18	195	340	10,81
401518	18	395	540	14,26
401519	20	195	340	12,19
401520	20	395	540	16,56
401521	22	215	340	13,11
401522	22	415	540	18,17
401523	24	215	340	14,26
401524	24	415	540	19,09
401525	25	215	340	14,26
401526	25	415	540	19,09
401527	28	240	370	18,40
401528	28	440	570	25,30
401529	30	240	370	23,00
401530	30	440	570	32,20
401531	32	235	370	27,60
401532	32	435	570	35,19
401533	35	235	370	32,20
401534	35	435	570	39,10
401535	38	235	370	40,25
401536	38	435	570	48,30
401537	40	235	370	44,85
401538	40	435	570	52,90

## EKONOMİK SERİ MATKAP MANDRENLERİ

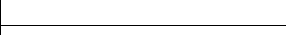
	KOD NO	GİRİŞ MİLİ	KAPASİTE	ÖZELLİK	FİYAT (USD)
	332050	1/4"	1 - 10 mm	Otomatik Mandren	7,71
	324205	1/4"	1 - 10 mm	Anahtarlı Mandren	10,99
	332049	1/4"	1 - 10 mm	Otomatik Mandren	9,52
	401506	1/4"	1 - 13 mm	Anahtarlı Mandren	3,91
	401508	3/8"	1 - 13 mm	Anahtarlı Mandren	3,45

## EKONOMİK SERİ KIRICI UÇLAR

	KOD NO	UÇ TİPİ	AÇIKLAMA	BOYUTLAR (mm)	FİYAT (USD)
	401344		Murç	250	2,17
	401347		Keski	20x 250	2,81
	401345		Murç	300	5,75
	401346		Murç	450	7,31
	401348		Keski	25 x 300	5,75
	401349		Keski	25 x 400	7,31
	401036		Murç	410	19,32
	401045		Keski	35 x 410	19,32

## EKONOMİK SERİ DAİRE TESTERE BİÇAKLARI

	KOD NO	ÇAP (mm)	KESİM GENİŞLİĞİ (mm)	GÖBEK ÇAP (mm)	DIŞ SAYISI	UYGULAMA	MAKİNE TİPİ	FİYAT (USD)
	402087	185	2,2	30/20	40	Ahşap	Daire testere	13,64
	402363	185	2,2	30/20	60	Ahşap	Daire testere	14,07
	402141	235	2,6	30/25.4	48	Ahşap	Daire testere	26,34
	402142	235	2,6	30/25.4	60	Ahşap	Daire testere	27,05

## EKONOMİK SERİ METAL MATKAP UÇLARI

	KOD NO	ÇAP (mm)	ÇALIŞMA UZUNLUĞU (mm)	TOPLAM UZUNLUK (mm)	AMBALAJ İÇERİĞİ (ADET)	FİYAT (USD)
	401167	1.0	12	34	10	1,59
	401172	1.5	20	43	10	1,59
	401177	2.0	24	49	10	1,82
	401182	2.5	30	57	10	2,05
	401187	3.0	33	61	10	3,40
	401192	3.5	39	70	10	3,63
	401197	4.0	43	75	10	4,42
	401202	4.5	47	80	10	5,15
	401207	5.0	52	86	10	6,33
	401212	5.5	57	93	10	8,07
	401217	6.0	57	93	10	9,06
	401222	6.5	63	101	10	9,68
	401227	7.0	69	109	10	11,96
	401232	7.5	69	109	10	13,62
	401237	8.0	75	117	10	17,66
	401242	8.5	75	117	10	18,93
	401247	9.0	81	125	10	11,71
	401252	9.5	81	125	10	12,67
	401257	10.0	87	133	10	14,74
	401262	10.5	87	133	5	15,99
401267	11.0	94	142	5	18,42	
401272	11.5	94	142	5	20,06	
401277	12.0	101	151	5	22,89	
401282	12.5	101	151	5	24,84	
401287	13.0	101	151	5	26,66	

## EKONOMİK SERİ METAL MATKAP UÇ SETİ

	KOD NO	AÇIKLAMA	FİYAT (USD)
	401288	13 Parça, Ekonomik Seri Metal Matkap uç seti	7,50



## SDS-PLUS DELİCİ UÇLARI



KOD NO	ÇAP (mm)	ÇALIŞMA UZUNLUĞU (mm)	TOPLAM UZUNLUK (mm)	FİYAT (EUR)
782401 (750100)*	4	50	110	2,60
782404 (750101)*	5	50	110	2,05
782406 (750102)*	5	100	160	2,30
782410 (750103)*	5,5	50	110	2,48
782411 (750104)*	5,5	100	160	2,48
782415 (750105)*	6	50	110	2,05
782416 (750106)*	6	100	160	2,23
782417 (751707)*	6	150	210	3,91
782418 (751708)*	6	200	260	5,06
782422 (750107)*	6,5	50	110	2,48
782423 (750108)*	6,5	100	160	2,81
782429 (750109)*	7	50	110	2,48
782430 (750110)*	7	100	160	2,76
782431 (751715)*	7	150	210	4,30
782432 (750111)*	8	50	110	2,32
782433 (750112)*	8	100	160	2,48
782434 (750113)*	8	150	210	2,94
782435 (750114)*	8	200	260	3,75
782436 (750115)*	8	250	300	5,29
782438 (750161)*	8	410	460	10,33
782441 (750160)*	9	100	160	4,12
782442 (750117)*	9	150	210	3,89
782444 (750118)*	10	50	110	2,81
782445 (750119)*	10	100	160	2,81
782446 (750120)*	10	150	210	3,66
782447 (750121)*	10	200	260	4,12
782448 (750122)*	10	250	300	5,96
782450 (750123)*	10	410	460	10,05
782451 (750168)*	10	550	610	13,73
782454 (750124)*	11	100	160	4,32
782456 (750125)*	11	200	260	5,84
782458 (750126)*	12	100	160	3,61
782459 (750127)*	12	150	210	4,42
782460 (750128)*	12	200	260	5,82
782461 (750129)*	12	250	300	6,58
782463 (750130)*	12	410	460	10,42
782464 (750162)*	12	550	600	14,56
782467 (750131)*	13	100	160	4,90
782468 (751724)*	13	150	210	6,95
782469 (750132)*	13	200	260	7,80
782471 (750133)*	14	100	160	5,29
782472 (750134)*	14	150	210	5,66
782474 (750135)*	14	250	300	7,75
782475 (750136)*	14	410	460	11,22
782476 (750163)*	14	550	600	16,86
782479 (750137)*	15	100	160	5,66
782481 (750138)*	15	200	260	8,14
782483 (750139)*	16	100	160	6,76
782484 (750140)*	16	150	210	7,91
782486 (750141)*	16	250	300	12,44
782487 (750142)*	16	410	460	15,89
782488 (750164)*	16	550	600	16,31
782491 (751730)*	17	150	210	14,03
782492 (751765)*	18	150	210	12,37
782494 (751767)*	18	250	300	16,84
782495 (751768)*	18	410	460	17,94
782498 (751771)*	19	150	210	14,65
782499 (751773)*	19	410	460	19,02
782500 (751774)*	20	150	210	15,32
782502 (751776)*	20	250	300	18,65
782503 (751777)*	20	410	460	19,27
782504 (751778)*	20	550	600	20,70
782506 (751780)*	22	200	260	21,14
782507 (751781)*	22	250	300	22,08
782508 (751782)*	22	410	460	22,75
782513 (751787)*	24	200	260	22,33
782514 (751788)*	24	250	300	22,33
782515 (751789)*	24	410	460	28,08
782516 (751790)*	25	200	260	23,69
782517 (751791)*	25	250	300	26,04
782518 (751792)*	25	410	460	32,02

744085

SDS-Plus Mandren Adaptörü

6,69

(\*) Parantez içinde belirtilen kodlar aynı teknik özelliklere sahip eski kodlardır.

## SDS-PLUS DELİCİ UÇLAR 10'luk kutu içerisinde

		KOD NO	ÇAP (mm)	ÇALIŞMA UZUNLUĞU (mm)	TOPLAM UZUNLUK (mm)	FİYAT (EUR)
		782613 (752611)	6	50	110	20,33
		782614 (752612)	6	100	160	22,54
		752613	6	150	210	39,54
		782623 (752620)	7	50	110	25,05
		752621	7	100	160	27,78
		782625 (752622)	7	150	210	43,22
		752623	8	50	110	23,50
		782627 (752624)	8	100	160	25,05
		782628 (752625)	8	150	210	28,45
		752628	9	100	160	38,90
		752629	9	150	210	38,90
		782635 (752632)	10	100	160	28,52
		752633	10	150	210	36,75
		782643 (752640)	12	100	160	36,11
	782644 (752641)	12	150	210	44,78	

(\*) Parantez içinde belirtilen kodlar aynı teknik özelliklere sahip eski kodlardır.

## SDS-PLUS DELİCİ UÇLAR 25'lik kutu içerisinde



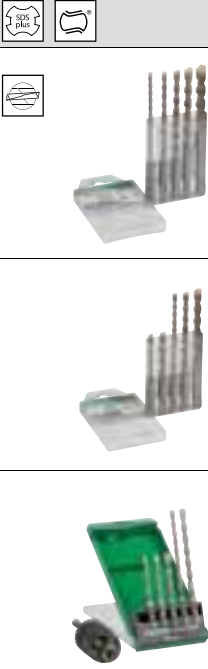

		KOD NO	ÇAP (mm)	ÇALIŞMA UZUNLUĞU (mm)	TOPLAM UZUNLUK (mm)	FİYAT (EUR)
		782662 (752654)	6	50	110	49,89
		782663 (752655)	6	100	160	55,20
		752656	6	150	210	96,76
		752662	7	50	110	61,23
		752663	7	100	160	69,48
		752664	7	150	210	108,03
		752665	8	50	110	57,45
		782674 (752666)	8	100	160	61,23
		752667	8	150	210	69,55
		752669	9	100	160	95,27
		752670	9	150	210	102,03
		752672	10	100	160	71,02
		752673	10	150	210	89,93

(\*) Parantez içinde belirtilen kodlar aynı teknik özelliklere sahip eski kodlardır.

## SDS-PLUS UÇ SETLERİ



		KOD NO	AÇIKLAMA	FİYAT (EUR)
		751023	5 Parça SDS-Plus uç seti  Ø 5 - 6 - 8 - 10 - 12 x 160 mm	16,56
		751024	5 Parça SDS-Plus uç seti  Ø 6 - 8 x 110 mm Ø 6 - 8 - 10 x 160 mm	13,00
		751030	5 Parça SDS-Plus uç seti  Ø 6 - 8 x 110 mm Ø 6 - 8 - 10 x 160 mm Anahtarsız mandren	48,07

## SDS-MAX DELİCİ UÇLARI



 		KOD NO	ÇAP (mm)	ÇALIŞMA UZUNLUĞU (mm)	TOPLAM UZUNLUK (mm)	FİYAT (EUR)
		750910	12	200	340	27,62
		750911	12	400	540	35,28
		750912	12	550	690	45,17
		750913	12	800	940	52,28
		750914	14	200	340	30,18
		750915	14	400	540	38,25
		750916	14	800	940	58,49
		750917	15	200	340	34,02
		750918	15	400	540	40,87
		754301 (750919)*	16	200	400	36,57
		754302 (750920)*	16	400	570	40,89
		754303 (750921)*	16	800	940	59,34
		754305 (750922)*	18	200	400	36,75
		754306 (750923)*	18	400	570	42,09
		754307 (750924)*	18	800	940	62,47
		754309 (750925)*	20	200	400	37,51
		754310 (750926)*	20	400	570	44,78
		754311 (750927)*	20	800	920	61,18
		754313 (750928)*	22	200	400	39,74
		754314 (750929)*	22	400	570	44,21
		754315 (750930)*	22	800	920	63,78
		754316 (751079)*	22	1200	1320	161,74
		754317 (750931)*	24	200	320	45,59
		754318 (750932)*	24	400	520	53,82
		754319 (750933)*	25	200	320	42,73
		754320 (750934)*	25	400	520	52,51
		754321 (750935)*	25	800	920	76,64
		754322 (751081)*	25	1200	1320	164,63
		754323	26	400	520	63,46
		754324 (750936)*	28	250	370	51,77
		754325 (750937)*	28	450	570	59,39
		754326 (750938)*	28	550	670	77,56
		754328 (751084)*	28	1200	1320	172,52
		754329 (750939)*	30	250	370	52,95
		754330 (750940)*	30	450	570	70,01
	754332 (750941)*	32	250	370	54,95	
	754333 (750942)*	32	450	570	70,75	
	754334 (750943)*	32	800	920	100,92	
	754335 (751088)*	32	1200	1320	177,05	
	754336 (750944)*	35	250	370	70,01	
	754337 (750945)*	35	450	570	80,18	
	754338 (750946)*	35	550	670	98,74	
	754343 (750947)*	38	250	370	80,78	
	754344 (750948)*	38	450	570	92,67	
	754345 (750949)*	40	250	370	94,90	
	754346 (750950)*	40	450	570	112,22	
	754347 (750951)*	40	800	920	143,50	
	754349 (751021)*	45	450	570	152,88	
	754350 (751098)*	45	800	920	202,08	
	754351 (751022)*	50	450	570	192,12	
	754352 (751099)*	52	450	570	192,76	
	751006	SDS-Max / SDS-Plus Adaptörü				44,11

(\* Parantez içinde belirtilen kodlar aynı teknik özelliklere sahip eski kodlardır.)

## SDS-MAX ÇOK ELMASLI DELİCİ UÇLAR

 	KOD NO	ÇAP (mm)	ÇALIŞMA UZUNLUĞU (mm)	TOPLAM UZUNLUK (mm)	FİYAT (EUR)
	751653	45	170	310	144,92
	751654	45	410	550	169,51
	750952	45	450	590	196,58
	751655	45	850	990	201,66
	751656	55	170	310	166,89
	751657	55	410	550	192,33
	751658	55	850	990	235,91
	751659	65	170	310	183,75
	751660	65	410	550	210,47
	751661	65	850	990	245,23
	751662	80	170	310	207,28
	751663	80	410	550	233,93
	751664	80	850	990	310,41

## KAROT UÇLAR ve ADAPTÖR PROGRAMI

 	KOD NO	ÇAP (mm)	ÇALIŞMA UZUNLUĞU (mm)	FİYAT (EUR)
Karot uçlar 	751060	45	80	89,01
	751061	50	80	95,54
	751062	55	80	98,88
	751063	68	80	110,40
	751064	82	80	128,52
	751065	90	80	148,33
	751066	100	80	161,46
	751067	125	80	214,20
	751068	150	80	247,11
	Merkezleyici	751069	11	135
Adaptörler	751070	SDS - Max	200	42,41
	751071	SDS - Max	460	48,97

## KIRICI UÇLAR



### SDS-PLUS

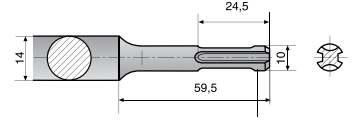

	KOD NO	AÇIKLAMA	BOYUTLAR (mm)	FİYAT (EUR)
	751590	Murç	250	5,66
	751591	Keski	20 x 250	5,66
	751592	Geniş Keski	40 x 250	11,45
	751595	Fayans Keski	40 x 250	10,49
	751599	Fayans Keski	40 x 260	14,31
	751594	Dluklu Keski	22 x 250	11,52



### SDS-MAX

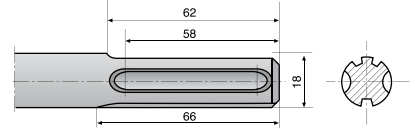

	KOD NO	AÇIKLAMA	BOYUTLAR (mm)	FİYAT (EUR)
	750990	Murç	280	7,57
	750991	Murç	400	8,90
	750992	Murç	600	13,71
	751032	Keskinleşen Murç	400	13,39
	750993	Keski	25 x 280	7,57
	750994	Keski	25 x 400	8,90
	750995	Keski	25 x 600	10,07
	750997	Geniş Keski	50 x 400	9,98
	751034	Geniş Keski	80 x 300	17,69
	750999	Geniş Keski	115 x 350	31,88
	751005	Fayans Keski	50 x 300	14,90
	751039	Fayans Keski	50 x 300	17,69
	750996	Oluklu Keski	26 x 300	16,72
	751000	Oluklu Keski	32 x 300	24,84
	751009	Asfalt Keski	75-110 x 400	54,05

## KIRICI UÇLAR



### ALTIGEN 13 mm

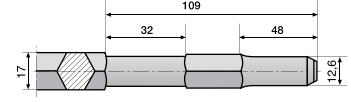





	KOD NO	AÇIKLAMA	BOYUTLAR (mm)	FİYAT (EUR)
	751500	Murç	280	7,64
	751501	Murç	450	8,23
	751502	Keski	20 x 280	7,64
	751503	Keski	20 x 450	8,23
	751505	Geniş Keski	50 x 450	19,83
	751509	Geniş Keski	80 x 400	33,60
	751507	Oluklu Keski	30 x 270	20,68
	751557	Oluklu Keski	22 x 250	26,86

DH 28Y, DH 40YB, H 41SA, H 45SA modelleri için

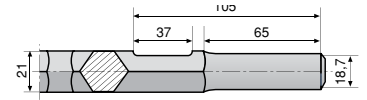

### ALTIGEN 19 mm



	KOD NO	AÇIKLAMA	BOYUTLAR (mm)	FİYAT (EUR)
	751533	Murç	460	14,95
	751536	Keski	25 x 460	14,95

H 55SA modeli için



### ALTIGEN 28 mm

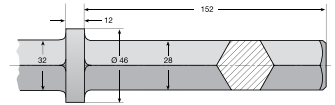

	KOD NO	AÇIKLAMA	BOYUTLAR (mm)	FİYAT (EUR)
	751571	Murç	550	31,07
	751572	Keski	35 X 550	33,19
	751573	Geniş Keski	76 X 500	32,84
	751574	Kürek	125 X 480	86,69





H 90SG modeli için

## KIRICI UÇLAR

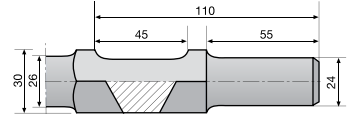

## ALTIGEN 30 mm







	KOD NO	AÇIKLAMA	BOYUTLAR (mm)	FİYAT (EUR)
	751543	Murç	400	21,85
	751544	Keski	35 x 410	21,85
	751545	Geniş Keski	80 x 400	33,35
	751542	Kürek	135 x 450	85,86
<i>H 65SB2, H 65SB, H 65SC, H 70SA modelleri için</i>				

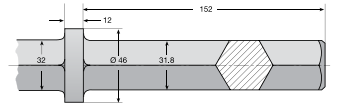

## ALTIGEN 32 mm

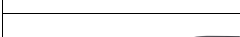
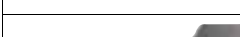
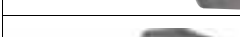

	KOD NO	AÇIKLAMA	BOYUTLAR (mm)	FİYAT (EUR)
	751581	Murç	430	28,29
	751582	Murç	550	28,91
	751583	Keski	32 x 550	31,07
	751584	Geniş Keski	80 x 550	42,37
	751585	Kürek	140 x 540	187,80
<i>H 90SC modeli için</i>				

## HSS-G DIN 338 TAŞLANMIŞ METAL MATKAP UÇLARI (GÜMÜŞ SERİ)



KOD NO	ÇAP (mm)	ÇALIŞMA UZUNLUĞU (mm)	TOPLAM UZUNLUK (mm)	AMBALAJ İÇERİĞİ (ADET)	FİYAT (EUR)
780261	1.0	12	34	10	8,51
780267	1.5	18	40	10	8,51
780273	2.0	24	49	10	7,64
780279	2.5	30	57	10	7,64
780285	3.0	33	61	10	7,64
780291	3.5	39	70	10	8,81
780297	4.0	43	75	10	9,50
780303	4.5	47	80	10	10,67
780309	5.0	52	86	10	11,27
780315	5.5	57	93	10	14,24
780321	6.0	57	93	10	14,81
780327	6.5	63	101	10	17,66
780333	7.0	69	109	10	20,31
780339	7.5	69	109	10	22,08
780345	8.0	75	117	10	24,68
780351	8.5	75	117	5	14,70
780357	9.0	81	125	5	16,01
780363	9.5	81	125	5	18,08
780369	10.0	87	133	5	19,39
780375	10.5	87	133	5	23,07
780381	11.0	94	142	5	24,68
780387	11.5	94	142	5	27,53
780393	12.0	101	151	5	29,60
780399	12.5	101	151	5	32,38
780405	13.0	101	151	5	33,99

## HSS-CO DIN 338 METAL MATKAP UÇLARI (ALTIN SERİ)



KOD NO	ÇAP (mm)	ÇALIŞMA UZUNLUĞU (mm)	TOPLAM UZUNLUK (mm)	AMBALAJ İÇERİĞİ (ADET)	FİYAT (EUR)
780551	1.0	12	34	10	13,62
780557	1.5	18	40	10	13,62
780563	2.0	24	49	10	12,35
780569	2.5	30	57	10	12,35
780575	3.0	33	61	10	12,35
780581	3.5	39	70	10	13,89
780587	4.0	43	75	10	15,27
780593	4.5	47	80	10	17,11
780599	5.0	52	80	10	18,38
780605	5.5	57	93	10	23,00
780611	6.0	57	93	10	24,24
780617	6.5	63	101	10	28,75
780623	7.0	69	109	10	33,42
780629	7.5	69	109	10	36,50
780635	8.0	75	117	10	40,85
780641	8.5	75	117	5	24,08
780647	9.0	81	125	5	26,13
780653	9.5	81	125	5	29,67
780659	10.0	87	133	5	32,13
780665	10.5	87	133	5	38,34
780671	11.0	94	142	5	40,96
780677	11.5	94	142	5	45,79
780683	12.0	101	151	5	49,31
780689	12.5	101	151	5	54,10
780695	13.0	101	151	5	56,88

## AHŞAP MATKAP UÇLARI



KOD NO	ÇAP (mm)	ÇALIŞMA UZUNLUĞU (mm)	TOPLAM UZUNLUK (mm)	AMBALAJ İÇERİĞİ (ADET)	FİYAT (EUR)
781902	4.0	45	75	1	0,52
781903	5.0	50	86	1	0,55
781904	6.0	55	92	1	0,64
781905	7.0	75	109	1	0,66
781906	8.0	75	117	1	0,74
781907	9.0	80	125	1	0,84
781908	10.0	85	133	1	1,01





**BETON MATKAP UÇLARI**

	KOD NO	ÇAP (mm)	ÇALIŞMA UZUNLUĞU (mm)	TOPLAM UZUNLUK (mm)	AMBALAJ İÇERİĞİ (ADET)	FİYAT (EUR)
	780851	3.0	40	70	1	1,17
780852	4.0	50	85	1	1,20	
780853	5.0	50	85	1	1,08	
780857	6.0	60	100	1	1,17	
780864	7.0	60	100	1	1,36	
780866	8.0	80	120	1	1,45	
780870	9.0	80	120	1	1,79	
780871	10.0	80	120	1	1,89	
780875	12.0	90	150	1	2,60	
780879	13.0	90	150	1	3,63	
780880	14.0	90	150	1	4,05	
780884	15.0	100	160	1	4,99	
780885	16.0	100	160	1	5,08	
780888	18.0	100	160	1	7,22	
780891	20.0	100	160	1	9,75	
780892	20.0	350	400	1	15,87	
780894	22.0	350	400	1	17,02	

**KALIPÇI TAŞLAMA FREZELERİ**

	KOD NO	Sap (mm)	Çap (mm)	Kesici Uzunluk (mm)	Toplam Uzunluk (mm)	Paket İçeriği (Adet)	FİYAT (EUR)
	780734	6	9,6	19	64	1	14,56
780733	6	8	19	64	1	13,50	
780736	6	12,7	25	70	1	22,66	

	KOD NO	Sap (mm)	Çap (mm)	Kesici Uzunluk (mm)	Toplam Uzunluk (mm)	Paket İçeriği (Adet)	FİYAT (EUR)
	780741	6	9,6	19	64	1	14,70
780740	6	8	19	64	1	13,41	
780743	6	12,7	25	70	1	23,12	

	KOD NO	Sap (mm)	Çap (mm)	Kesici Uzunluk (mm)	Toplam Uzunluk (mm)	Paket İçeriği (Adet)	FİYAT (EUR)
	780748	6	9,6	8	54	1	12,08
780747	6	8	6	52	1	10,79	

	KOD NO	Sap (mm)	Çap (mm)	Kesici Uzunluk (mm)	Toplam Uzunluk (mm)	Paket İçeriği (Adet)	FİYAT (EUR)
	780755	6	9,6	16	60	1	14,70
780754	6	8	15	60	1	13,46	
780756	6	12,7	22	67	1	23,10	

	KOD NO	Sap (mm)	Çap (mm)	Kesici Uzunluk (mm)	Toplam Uzunluk (mm)	Paket İçeriği (Adet)	FİYAT (EUR)
	780761	6	9,6	19	64	1	14,40
780760	6	8	20	65	1	13,46	
780763	6	12,7	25	70	1	22,68	







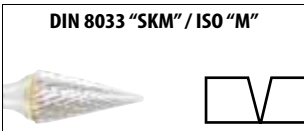



	KOD NO	Sap (mm)	Çap (mm)	Kesici Uzunluk (mm)	Toplam Uzunluk (mm)	Paket İçeriği (Adet)	FİYAT (EUR)
	780768	6	9,6	19	64	1	15,34
780767	6	8	19	64	1	13,87	
780769	6	12,7	25	70	1	23,94	

	KOD NO	Sap (mm)	Çap (mm)	Kesici Uzunluk (mm)	Toplam Uzunluk (mm)	Paket İçeriği (Adet)	FİYAT (EUR)
	780774	6	9,6	19	64	1	26,20
780773	6	8	19	64	1	15,11	
780775	6	12,7	32	77	1	30,80	





	KOD NO	Sap (mm)	Çap (mm)	Kesici Uzunluk (mm)	Toplam Uzunluk (mm)	Paket İçeriği (Adet)	FİYAT (EUR)
	780780	6	9,6	30	76	1	18,38
780779	6	8	25,4	70	1	15,30	
780781	6	12,7	32	77	1	23,94	

	KOD NO	Sap (mm)	Çap (mm)	Kesici Uzunluk (mm)	Toplam Uzunluk (mm)	Paket İçeriği (Adet)	FİYAT (EUR)
	780784	6	6	20	50	1	11,68
780785	6	9,6	16	64	1	20,50	
780786	6	12,7	22	71	1	23,94	



## BITS UÇLAR

	KOD NO	UÇ TİPİ / ÖLÇÜ	BOY (mm)	ADEDİ	FIYAT (EUR)
	752252	PH 1	25	3	1,89
	752256	PH 1	25	25	9,22
	752253	PH 2	25	3	1,89
	752257	PH 2	25	25	9,22
	752254	PH 3	25	3	1,89
	752263	PH 1	50	3	5,50
	752264	PH 2	50	3	5,50
	752265	PH 3	50	3	5,50
	752266	PH 2	109	2	8,03
	752376	PH 2	136,4	2	10,90
	752267	PH 2	152	2	10,37
	752268	PH 3	152	2	10,37
	752272	PZ 1	25	3	1,89
	752276	PZ 1	25	25	9,22
	752273	PZ 2	25	3	1,89
	752277	PZ 2	25	25	9,22
	752274	PZ 3	25	3	1,89
	752285	PZ 1	50	3	7,68
	752286	PZ 2	50	3	5,50
	752287	PZ 3	50	3	5,50
	752288	PZ 2	109	2	8,03
	752379	PZ 2	136,4	2	10,90
	752289	PZ 2	152	2	10,37
	752290	PZ 3	152	2	10,37
	752291	4.0X0.5	25	3	2,69
	752292	4.5X0.6	25	3	2,69
	752293	5.5X0.8	25	3	2,69
	752294	6.0X1.0	25	3	2,69
	752295	6.5X1.2	25	3	2,69
	752307	T10	25	3	3,20
	752308	T15	25	3	3,20
	752309	T20	25	3	3,20
	752243	T20	25	25	20,63
	752310	T25	25	3	3,20
	752244	T25	25	25	20,63
	752311	T27	25	3	3,20
	752312	T30	25	3	3,20
	752313	T40	25	3	3,20
		752318	T10	50	3
752319		T15	50	3	6,72
752320		T20	50	3	6,72
752321		T25	50	3	6,72
752322		T27	50	3	6,72
752323		T30	50	3	6,72
752324		T40	50	3	6,72
		752331	TX8	25	3
	752332	TX10	25	3	4,07
	752333	TX15	25	3	4,07
	752334	TX20	25	3	4,07
	752335	TX25	25	3	4,07
	752336	TX27	25	3	4,07
	752337	TX30	25	3	4,07
	752338	TX40	25	3	4,07



## DARBELİ BITS UÇLAR

	KOD NO	uç tipi / ölçü	BOY (mm)	PAKET ADEDİ	FİYAT (EUR)
	751171	PH 1	38	3	7,04
	751172	PH 1	38	3	7,04
	751173	PH 3	38	3	7,04
	751176	PZ 1	38	3	7,04
	751177	PZ 2	38	3	7,04
	751178	PZ 3	38	3	7,04
	751181	T15	38	3	7,04
	751182	T20	38	3	7,04
	751183	T25	38	3	7,04
	751184	T30	38	3	7,04
	751185	T45	38	3	7,04





## DARBELİ BITS UÇ SETİ

	KOD NO	AÇIKLAMA	FİYAT (EUR)
	751190	<b>21 Parça Darbeli Uç Seti,</b> Yıldız Uç - PH1, 2xPH2, 2xPH3 Pozitiv Uç - PZ1, 2xPZ2, 2xPZ3 Torx Uç - 2xT15, 2xT20, 2xT25, 2xT30, 2xT40 Manyetik Uç Tutucu	50,42

## BITS UÇ GİRİŞLİ MANYETİK LOKMALAR

	KOD NO	uç ölçüsü (mm)	BOY (mm)	ADEDİ	FİYAT (EUR)
	752351	5.5	45	1	5,84
	752352	6	45	1	5,84
	752353	7	45	1	5,84
	752354	8	45	1	5,84
	752355	9	45	1	5,84
	752356	10	45	1	5,84
	752357	11	45	1	5,84
	752358	12	45	1	5,84
	752359	13	45	1	5,84
	752360	17	50	1	8,00

## MANYETİK BITS UÇ ADAPTÖRÜ

	KOD NO	AÇIKLAMA	BOY (mm)	ADEDİ	FİYAT (EUR)
	752398	1/4" m	41	1	6,12
	752394	1/4" manyetik bits uç adaptörü Standart	60	1	3,98
	750480	1/4" manyetik bits uç adaptörü Ekstra mknatıslama gücü	60	1	10,60
	752390	1/4" manyetik bits uç adaptörü Derinlik ayarlı	60	1	8,83
	752389	SDS-Plus manyetik bits uç adaptörü	75	1	8,33

## BITS UÇ SETLERİ

	KOD NO	AÇIKLAMA	FIYAT (EUR)
	710000	<p><b>42 Parça Uç Seti</b>            Ahşap Delici Uç - Ø 1.5, 2.5, 3, 4, 5 mm            Altıköşe Lokma - 5.5, 6, 7, 8, 10, 12, 13 mm            Çift Taraflı Düz Uç - 6 mm, L = 45 mm            Allen Uç - 2, 2.5, 3, 4, 5, 6 mm, L = 50 mm            Torx Uç - T10, T15, T20, T25, T30, T40, L = 50 mm            Düz Uç - 5, 6 mm, L = 50 mm            Çift Taraflı Yıldız Uç - PH1, PH3, L = 65 mm            Çift Taraflı Pozidriv Uç - PZ1, PZ2, PZ3, L = 65 mm            Yıldız Uç - PH2, L = 100 mm            Pozidriv Uç - PZ2, L = 100 mm            Çift Taraflı Yıldız Uç - 3 x PH2, L = 110 mm            Çift Taraflı Pozidriv Uç - 2 x PZ2, L = 110 mm            Manyetik Uç Tutucu            Taşıyıcı Kılıf, 10 Uç İçin            Adaptör Altıgen 1/4" → Kare 1/4"</p>	15,09
	751057	<p><b>60 Parça Uç Seti</b>            Yıldız Uç - PH0, PH1, PH2, PH3            Pozidriv Uç - PZ0, PZ1, PZ2, PZ3            Torx Uç - T10, T15, T20, T25, T30, T40            Allen Uç - 2, 3, 4, 5, 5.5, 6 mm            Düz Uç - 3, 4, 5, 6, 7 mm            Yıldız Uç - PH1, PH2, L = 65 mm            Düz Uç - 5, 7, L = 65 mm            Manyetik Uç Tutucu            Hızlı Değiştirilebilir Uç Tutucu, L = 120 mm            Esnek Mil, L = 145 mm            Saatçi Tornavida, Yıldız Uç - PH0x25, PH0x50, Düz Uç - 2.4x25, 3x50 mm            Allen Anahtar 1/4" Kare Uçlu, Yuvarlak Tip Uç Tutamağı            Adaptör, Altıgen 1/4" → Kare 1/4"            Cırcır Mekanizmalı 1/4" Uç Tutuculu Kısa Tornavida            Uç Tutuculu Tornavida            Adaptör iç altıgen 1/4" → İç Kare 1/4"            Kare Lokmalar - 5, 6, 7, 8, 9, 10, 11, 12, 13 mm            1/2, 15/32, 7/16, 3/5, 11/32, 15/16, 3/4, 7/12, 3/16 inç</p>	27,69
	715000	<p><b>61 Parça Uç Seti</b>            Yıldız Uç - PH1, 3xPH2, 2xPH3            Pozidriv Uç - 5xPZ1, 10xPZ2, 5xPZ3            Torx Uç - T10, 2xT15, 2xT20, 2xT25, T27, T30, T40            Dişi Torx - TX10, TX15, TX20, TX25, TX27, TX30            Allen Uç - 2, 2.5, 3, 4, 5, 5.5, 6, 7, 8 mm            Düz Uç - 4, 4.5, 5, 6, 7, 8 mm            Manyetik Uç Tutuculu Adaptör</p>	10,03

## BITS UÇ SETLERİ



	KOD NO	AÇIKLAMA	FİYAT (EUR)
	705315M	<p><b>112 Parça Uç Seti</b>            Yıldız Uç - PH0, PH1, PH2, PH3            Pozidriv Uç - PZ1, PZ2, PZ3            Torx Uç - T10, T15, T20, T25, T27, T30, T40            Allen Uç - 2, 3, 4, 5, 6, 7 mm            Düz Uç - 3, 4, 5, 6, 7, 8 mm            Robertson 1, 2, 3            Pozidriv Uç - PZ1, 2xPZ2, PZ3, L = 50 mm            Torx Uç - T10, T15, T20, L = 50 mm            Allen Uç - 2, 3, 4, 5, 6 mm, L = 50 mm            Düz Uç - 6, 8, 10, 12 mm, L = 50 mm            Robertson 1, 2, 3, L = 50 mm            Manyetik Uç Tutucu            Hızlı Değiştirilebilir Manyetik Uç Tutucu            1/4" Esnek Mil L = 280 mm            1/4" Uç Tutuculu Tornavida            4 x Vida Tutucu            1/4" Havşa Açıcı            1/4" Lokma - 3/16, 7/32, 1/4, 9/32, 5/16, 11/32, 3/8, 7/16, 1/2 inç                              5, 6, 7, 8, 9, 10, 11, 12, 13 mm            Ahşap için Yaprak Uç - 10, 12, 20 mm            1/4" Uç Girişli Metal Matkap Uçları - 1.5, 2, 2.5, 3, 3.2, 3.5, 4, 4.5, 4.8, 5, 5.5, 6, 6.5 mm            1/4" Uç Girişli Ahşap Matkap Uçları - 3, 3.2, 3.5, 4, 4.5, 4.8, 5, 5.5, 6, 6.5, 7, 7.5, 8 mm            1/4" Uç Girişli Beton Matkap Uçları - 3, 4, 5, 6, 8, 10 mm</p>	47,10
	750362	<p><b>24 Parça Uç Seti</b>            Yıldız Uç - PH1, PH2, PH3            Pozidriv Uç - PZ1, PH2, PH3            Lokma - 6, 7, 8, 10, 11, 13 mm            Allen Uç - 3, 4, 5 mm            Torx Uç - T10, T15, T20, T25, T30, T40            Manyetik Uç Tutucu            Adaptör Altıgen 1/4" → Kare 1/4"            Cırcır Anahtar</p>	16,86
	750363	<p><b>32 Parça Uç Seti</b>            Yıldız Uç - PH1, 2xPH2, PH3,            Pozidriv Uç - PZ1, PZ2, 2xPZ2            Lokma - 3.5, 4.5, 5.5, 6.5 mm            Allen Uç - 3, 4, 5, 6 mm            Torx Uç - T10, T15, T20, T25, T27, T30, T40            Dişi Torx Uç - TX10, TX15, TX20, TX25, TX27, TX30, TX40            Hızlı Değiştirilebilir Manyetik Uç Tutucu            Adaptör Altıgen 1/4" → Kare 1/4"</p>	11,25
	750365	<p><b>50 Parça Uç Seti</b>            Yıldız Uç - 2xPH1, 2xPH2, 2xPH3,            Pozidriv Uç - 2xPZ1, 2xPZ2, 2xPZ3            Düz Uç - 3.5, 4.5, 5.5, 6.5 mm            Allen Uç - 3, 4, 5, 6, 8 mm            Torx Uç - 2xT10, 2xT15, 2xT20, 2xT25, 2xT30, 2xT40, T27            Dişi Torx Uç - TX10, TX15, TX20, TX25, TX30, TX40            1/4" Uç Girişli Ahşap Matkap Ucu - Ø 3, 4, 5, 6 mm            1/4" Uç Girişli Metal Matkap Ucu - Ø 2, 3, 4, 5 mm            1/4" Havşa Açıcı Ø 12.4 mm            Hızlı Değiştirilebilir Manyetik Uç Tutucu</p>	22,77

## MANYETİK MATKAP AKSESUARLARI HSS METAL DELİCİ UÇ PROGRAMI

### HSS METAL DELİCİ UÇLAR KISA TİP, DELME BOYU 30 MM

	KOD NO	ÇAP (mm)	FİYAT (EUR)
	754401 (712120)*	12	17,11
754402 (712130)*	13	17,11	
754403 (712140)*	14	17,11	
754404 (712150)*	15	19,69	
754405 (712160)*	16	19,69	
754406 (712170)*	17	19,69	
754407 (712180)*	18	17,18	
754408 (712190)*	19	17,18	
754409 (712200)*	20	22,26	
754410 (712210)*	21	22,79	
754411 (712220)*	22	23,32	
754412	22,23	23,32	
754413 (712230)*	23	24,33	
754414 (712240)*	24	25,90	
754415 (712250)*	25	26,91	
754416	25,4	36,87	
754417 (712260)*	26	29,21	
754418 (712270)*	27	30,34	
754419 (712280)*	28	32,11	
754420 (712290)*	29	33,12	
754421 (712300)*	30	34,41	
754422 (712310)*	31	36,59	
754423 (712320)*	32	37,54	
754424 (712330)*	33	40,78	
754425 (712340)*	34	41,86	
754426 (712350)*	35	42,99	
754427 (712436)*	36	44,11	
754428 (712437)*	37	45,36	
754429 (712438)*	38	46,48	
754430 (712439)*	39	47,75	
754431 (712440)*	40	51,77	
754432 (712441)*	41	59,25	
754433 (712442)*	42	60,63	
754434 (712443)*	43	62,05	
754435 (712444)*	44	63,48	
754436 (712445)*	45	74,29	
754437 (712446)*	46	75,72	
754438 (712447)*	47	77,28	
754439 (712448)*	48	78,84	
754440 (712449)*	49	80,32	
754441 (712450)*	50	81,95	
754442 (712451)*	51	95,52	
754443 (712452)*	52	97,91	
754444 (712553)*	53	100,33	
754445 (712454)*	54	102,83	
754446 (712455)*	55	105,39	
754447 (712456)*	56	111,37	
754448 (712457)*	57	114,03	
754449 (712458)*	58	116,68	
754450 (712459)*	59	119,42	
754451 (712460)*	60	122,20	



(\*) Parantez içinde belirtilen kodlar aynı teknik özelliklere sahip eski kodlardır.

	KOD NO	AÇIKLAMA	FİYAT (EUR)
	754495 (712070)*	Merkezleyici pim (kısa)	7,31
712071	Emniyet zinciri	34,90	
	712072	Özel kesim yağı 1 litre	15,46
	712073	Özel kesim yağı spreyi 400 ml	16,10

(\*) Parantez içinde belirtilen kodlar aynı teknik özelliklere sahip eski kodlardır.

## MANYETİK MATKAP AKSESUARLARI HSS METAL DELİCİ UÇ PROGRAMI

## HSS METAL DELİCİ UÇLAR UZUN TİP, DELME BOYU 55 MM

	KOD NO	ÇAP (mm)	FİYAT (EUR)
	754501	12	24,77
	754502	13	24,77
	754503 (713140)*	14	24,77
	754504 (713150)*	15	28,43
	754505 (713160)*	16	28,43
	754506 (713170)*	17	28,43
	754507 (713180)*	18	24,77
	754508 (713190)*	19	24,77
	754509 (713200)*	20	32,20
	754510 (713210)*	21	32,89
	754511 (713220)*	22	33,72
	754512 (713230)*	23	35,58
	754513 (713240)*	24	37,40
	754514 (713250)*	25	38,89
	754515 (713260)*	26	42,18
	754516 (713270)*	27	44,23
	754517 (713280)*	28	46,53
	754518 (713290)*	29	48,02
	754519 (713300)*	30	49,52
	754520	31	53,34
	754521 (713320)*	32	54,60
	754522 (713333)*	33	64,65
	754523 (713334)*	34	66,03
	754524 (713335)*	35	67,48
	754525 (713336)*	36	68,98
	754526 (713337)*	37	70,56
	754527 (713338)*	38	72,01
	754528 (713339)*	39	73,74
	754529 (713340)*	40	79,56
	754530 (713341)*	41	92,28
754531 (713342)*	42	94,07	
754532 (713343)*	43	95,93	
754533 (713344)*	44	97,91	
754534 (713345)*	45	116,61	
754535 (713346)*	46	118,45	
754536 (713347)*	47	120,36	
754537 (713348)*	48	122,29	
754538 (713349)*	49	124,29	
754539 (713350)*	50	126,34	
754540 (713351)*	51	148,07	
754541 (713352)*	52	151,41	
754542 (713353)*	53	154,86	
754543 (713354)*	54	158,38	
754544 (713355)*	55	161,94	
754545 (713356)*	56	171,79	
754546 (713357)*	57	175,47	
754547 (713358)*	58	179,22	
754548 (713359)*	59	183,06	
754549 (713360)*	60	186,92	
	754594 (713070)*	Merkezleyici pim (uzun)	8,30

(\*) Parantez içinde belirtilen kodlar aynı teknik özelliklere sahip eski kodlardır.

## HSS METAL DELİCİ UÇ SETİ KISA TİP, DELME BOYU 30 MM

	KOD NO	AÇIKLAMA	FİYAT (EUR)
	712000	7 Parça Uç Seti (kısa boy, 30 mm)  Set içeriği: 2 ad. 14 mm 2 ad. 18 mm 2 ad. 22 mm 1 ad. Merkezleyici	162,89

## PANÇ TESTERELER

### HSS BİMETAL PANÇLAR METAL VE PASLANMAZ İÇİN

Pançlar için kesme derinliği  
38 mm



KOD NO	ÇAP (mm)	FİYAT (EUR)
752101	14	3,01
752102	16	3,08
752103	17	3,22
752104	19	3,52
752105	20	3,66
752106	21	3,77
752107	22	3,93
752108	24	4,05
752109	25	4,12
752110	27	4,58
752111	28	4,58
752112	29	4,85
752113	30	4,90
752114	32	5,06
752115	33	5,20
752116	35	5,31
752117	37	5,52
752118	38	5,77
752119	40	5,93
752120	41	6,05
752121	43	6,21
752122	44	6,35
752123	46	6,67
752124	48	6,90
752125	51	7,22
752126	52	7,36
752127	54	7,73
752128	55	7,84
752129	57	7,87
752130	59	8,21
752131	60	8,49
752132	64	8,72
752133	65	8,88
752134	67	9,61
752135	68	9,80
752136	70	9,89
752137	73	10,42
752138	76	10,86
752139	79	11,27
752140	83	11,73
752141	86	11,91
752142	89	12,93
752143	92	13,29
752144	95	13,73
752145	98	14,08
752146	102	14,56
752147	105	15,13
752148	108	15,57
752149	111	16,10
752150	114	16,95
752151	121	17,71
752152	127	19,07
752153	133	19,78
752154	140	20,86
752155	146	21,85
752156	152	22,68
752157	160	24,22
752158	165	24,98
752159	168	25,53
752160	178	27,00
752161	200	29,69
752162	210	37,40

### HSS BİMETAL PANÇ SETLERİ



KOD NO	ADI	AÇIKLAMA	FİYAT (EUR)
752171	Tesisatçı seti	Ø 19 - 22 - 29 - 38 - 44 - 57 mm 2 x adaptör ve düşürücü uç	56,40
752172	Elektrikçi seti	Ø 22 - 29 - 35 - 44 - 51 - 64 mm 2 x adaptör ve düşürücü uç	58,12
752173	Mekanikçi seti	Ø 19 - 22 - 29 - 35 - 38 - 44 - 51 - 57 - 64 mm 2 x adaptör ve düşürücü uç	82,20
752174	Kombi seti:	Ø 19 - 20 - 22 - 25 - 29 - 32 - 35 - 38 - 44 - 51 - 57 - 67 - 76 mm 2 x adaptör ve düşürücü uç	96,21



## PANÇ TESTERELER

## TCT PANÇLAR\* AHŞAP, BRİKET VE YTONG İÇİN

Pançlar için kesme derinliği  
50 mm

KOD NO	ÇAP (mm)	FİYAT (EUR)
754201	16	5,82
754202	19	5,93
754203	20	6,16
754204	22	6,42
754205	25	6,49
754206	27	6,62
754207	29	6,90
754208	32	6,95
754209	35	7,04
754210	38	7,08
754211	40	7,20
754212	44	7,27
754213	50	9,13
754214	51	9,13
754215	54	9,68
754216	57	9,68
754217	60	9,89
754218	63	11,78
754219	64	11,78
754220	65	11,78
754221	67	12,03
754222	68	12,03
754223	71	12,28
754224	73	12,40
754225	76	13,39
754226	79	14,26
754227	80	14,26
754228	82	14,65
754229	92	15,00
754230	102	16,54
754231	105	17,99
754232	111	18,79
754233	125	23,18
754234	133	25,23
754235	152	28,57

\* TCT pançlar, tungsten - karbit uçludur.

## PANÇLAR İÇİN ADAPTÖR VE AKSESUARLAR



## HSS BİMETAL PANÇLAR İÇİN ADAPTÖR VE AKSESUARLAR















KOD NO	MALZEME	BAĞLANTI	FİYAT (EUR)
752181	Adaptör 30 mm'den küçük pançlar için	6 mm altıgen	2,94
752182		9.5 mm altıgen	3,29
752183		11 mm altıgen	3,29
752184		SDS-plus	6,95
752185	Adaptör 30 mm - 38 mm (dahil) pançlar için	11 mm altıgen	3,38
752186	Adaptör 40 mm'den büyük pançlar için (kolay bağlantılı)	9.5 mm altıgen	6,90
752187		11 mm altıgen	6,99
752188		16 mm altıgen	8,14
752189		SDS plus	9,06
752190	Uzatma parçası	300 mm	4,92
752192	Merkezleme ucu	80 mm	1,33
752193	Merkezleme ucu	115 mm	1,33

## TCT PANÇLAR İÇİN ADAPTÖR VE AKSESUARLAR

KOD NO	MALZEME	BAĞLANTI	FİYAT (EUR)
754241	Adaptör 30 mm'den küçük TCT pançlar için	8.5 mm altıgen	3,04
754243		11 mm altıgen	3,04
754242	Adaptör, Hızlı bağlanabilen 30 mm ve üzeri TCT pançlar için	8.5 mm altıgen	6,07
754244		11 mm altıgen	6,46
754245	Merkezleme ucu	90 mm	1,33

## DEKUPAJ BIÇAKLARI KULLANIM PROGRAMI

	KOD NO	PAKET ADEDİ	TOPLAM UZUNLUK	ÇALIŞMA UZUNLUĞU	YÜKSEKLİK	KALINLIK	DİŞ ARALIĞI	İNÇ BAŞINA DİŞ SAYISI	MALZEME
			mm	mm	mm	mm	mm	TPI	
<b>PASLANMAZ ÇELİK</b>	750011	2	82,60	56,00	9,30	1,00	1,4	18	HM/TC
<b>METAL</b>	750038	5	91,50	65,00	7,50	1,00	Kademeli artan dişli	17-24	HSS
	750039	5	91,50	65,00	7,50	1,00	Kademeli artan dişli	17-24	BiM
	750014	5	132,00	105,00	9,50	1,00	1,0	24	HSS
	750033	5	100,40	75,00	8,60	1,00	Kademeli artan dişli	10-20	HSS
	750040	5	91,50	65,00	7,50	1,00	Kademeli artan dişli	11-14	HSS
	750041	5	91,50	65,00	7,50	1,00	Kademeli artan dişli	11-13	BiM
	750015	5	132,00	105,00	7,50	1,30	1,8	14	HSS
	750032	5	132,00	105,00	7,50	1,00	1,8	14	BiM
	750012	5	100,40	75,00	7,50	1,00	3,0	8	HSS
	750026	5	70,00	50,00	7,50	0,80	1,0	24	HSS
750025	5	70,00	50,00	7,50	1,00	1,8	14	HSS	
<b>AHŞAP - METAL</b>	750031	5	132,00	105,00	10,00	1,30	Kademeli artan dişli	5-10	BiM
<b>AHŞAP</b>	750036	5	76,60	54,00	4,70	1,30	1,4	18	HCS
	750042	5	91,50	65,00	7,50	1,00	Kademeli artan dişli	11-14	HCS
	750029	5	116,50	90,00	9,20	1,50	Kademeli artan dişli	8-12	HCS
	750019	5	100,40	75,00	7,20	1,50	2,5	10	HCS
	750044	5	100,40	75,00	7,20	1,50	2,7	10	HCS
	750021	5	100,40	75,00	9,50	1,30	3,0	8	HCS
	750043	5	100,40	75,00	7,20	1,30	Kademeli artan dişli	5-8	HCS
	750046	5	100,40	75,00	6,00	1,30	Kademeli artan dişli	5-8	HCS
	750028	5	132,00	107,00	7,20	1,70	4,0	6	HCS
	750045	5	100,40	75,00	7,20	1,50	Kademeli artan dişli	5-8	HCS
	750027	5	116,50	90,00	7,20	1,50	3,0	8	HCS
	750037	5	100,40	74,00	7,50	1,30	1,7	15	BiM
	750024	5	91,50	70,00	7,20	1,30	2,5	10	HCS
	750023	5	91,50	70,00	7,50	1,30	3,0	8	HCS
<b>ÖZEL</b>	750048	2	82,60	56,00	8,00	0,80	Kum Boyu 50		HM/TC
	750047	2	82,60	56,00	8,00	0,80	Kum Boyu 50		HM/TC
	750030	2	100,40	75,00	8,20	1,30	4,0	6	HM/TC
	750085	2	132,00	107,00	8,20	1,25	4,0	6	HM/TC

PASLANMAZ ÇELİK LEVHA	ÇİVİLİ AĞŞAP, KALAS	SAC PLAKA, BORU, PROFİL	ÇELİK SAC	ALUMİNYUM	BORU, PROFİL	PLASTİK	YUMUŞAK AĞAÇ, SUNTA	KONTRPLAK	SERT AĞAÇ	LAMİNAT PLAKA	KARTONPIYER	ELYAFLI ÇİMENTO	SERAMİK, FAYANS, CAM, KİREMIT	KOMPOZİT PANEL
														
•														
			1-3 mm											
			1-3 mm											
			1-3 mm	< 65 mm	•									
			1,5-10 mm	< 30 mm	•									
			2,5-6 mm											
			2,5-6 mm											
			2,5-6 mm	< 65 mm	•									
			2,5-6 mm	< 65 mm	•	< 65 mm								•
			3-15 mm	< 30 mm		3-100 mm								
			2,5-6 mm											
			1-3 mm											
	•	•		< 30 mm		3-100 mm			< 65 mm					
							2-15 mm	•		•				
							2-15 mm	•						
							2-65 mm							
							3-30 mm			•				
						3-100 mm	3-30 mm							
							4-50 mm							
							5-50 mm							
							5-50 mm							
							5-100 mm		< 100 mm					
							10-45 mm							
							10-65 mm							
						< 65 mm				•				
						3-100 mm	3-30 mm							
							4-50 mm							
													5-10 mm	
						< 65 mm				•	•	•	5-15 mm	
						< 80 mm				•	•	•		

## DEKUPAJ BIÇAKLARI

































META	PASLANMAZ ÇELİK	KOD NO	PAKET ADEDİ	FİYAT (EUR)
		750011	2	15,48
			82.6 / 56.0 x 9.3 x 1.0 mm	
META	METAL	KOD NO	PAKET ADEDİ	FİYAT (EUR)
		750038	5	4,67
			91.5 / 65.0 x 7.5 x 1.0 mm	
		750039	5	5,82
			91.5 / 65.0 x 7.5 x 1.0 mm	
		750014	5	7,96
			132.0 / 105.0 x 9.5 x 1.0 mm	
		750033	5	6,12
			100.4 / 75.0 x 6.6 x 1.0 mm	
		750040	5	4,67
			91.5 / 65.0 x 7.5 x 1.0 mm	
		750041	5	5,37
			91.5 / 65.0 x 7.5 x 1.0 mm	
		750015	5	7,96
			132.0 / 105.0 x 7.5 x 1.3 mm	

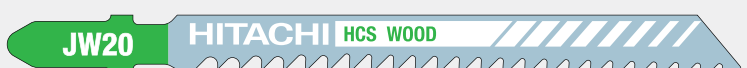



















METAL	METAL	KOD NO	PAKET ADEDİ	FİYAT (EUR)
		750032	5	9,15
		132.0 / 105.0 x 7.5 x 1.0 mm		
<b>JM41B HITACHI BIM METAL</b>				
		750012	5	4,81
		100.4 / 75.0 x 7.5 x 1.0 mm		
<b>JM20 HITACHI HSS METAL</b>				





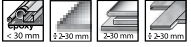





METAL	METAL	KOD NO	PAKET ADEDİ	FİYAT (EUR)
		750026	5	4,51
		70.0 / 50.0 x 7.5 x 0.8 mm		
<b>JUM10 HITACHI HSS METAL</b>				
		750025	5	4,51
		70.0 / 50.0 x 7.5 x 1.0 mm		
<b>JUM11 HITACHI HSS METAL</b>				























## DEKUPAJ BIÇAKLARI

METAL - AĞAÇ	METAL - AĞAÇ	KOD NO	PAKET ADEDİ	FİYAT (EUR)
		750031	5	9,89
		132.0 / 105.0 x 10.0 x 1.25 mm		
<b>JPU10 HITACHI BIM ALL PURPOSE PROGRESSOR</b>				









 AHŞAP 	KOD NO	PAKET ADEDİ	FIYAT (EUR)
	750036	5	5,04
		76.6 / 54.0 x 4.7 x 1.25 mm	 HCS
			
	750042	5	3,04
		91.5 / 65.0 x 7.5 x 1.0 mm	 HCS
			
	750029	5	6,92
		116.5 / 90.0 x 9.2 x 1.5 mm	 HCS
			
	750019	5	5,11
		100.4 / 75.0 x 7.2 x 1.5 mm	 HCS
			
	750044	5	4,65
		100.4 / 75.0 x 7.2 x 1.5 mm	 HCS
			
	750021	5	2,92
		100.4 / 75.0 x 7.2 x 1.25 mm	 HCS
			
	750043	5	5,82
		100.4 / 75.0 x 7.2 x 1.25 mm	 HCS
			
	750046	5	4,37
		100.4 / 75.0 x 6.0 x 1.25 mm	 HCS
			

 AHŞAP 	KOD NO	PAKET ADEDİ	FIYAT (EUR)
	750028	5	7,20
  		132.0 / 107.0 x 7.2 x 1.7 mm	 HCS
			
	750045	5	5,13
		100.4 / 75.0 x 7.2 x 1.5 mm	 HCS
			
	750027	5	7,64
		116.5 / 90.0 x 7.2 x 1.5 mm	 HCS
			
	750037	5	9,06
		100.4 / 74.0 x 7.5 x 1.25 mm	 HCS
			

 AHŞAP 	KOD NO	PAKET ADEDİ	FIYAT (EUR)
	750024	5	4,62
		91.5 / 74.0 x 7.5 x 1.25 mm	 HCS
			
	750023	5	3,38
		91.5 / 74.0 x 7.5 x 1.25 mm	 HCS
			

 ÖZEL 	KOD NO	PAKET ADEDİ	FIYAT (EUR)
	750048	2	7,04
		82.6 / 56.0 x 8.0 x 0.8 mm	 HM  TC
			
	750047	2	7,04
		82.6 / 56.0 x 8.0 x 0.8 mm	 HM  TC
			
	750030	2	15,55
		100.4 / 75.0 x 8.2 x 1.25 mm	 HM  TC
			
	750085	2	29,19
		132.0 / 107.0 x 8.2 x 1.25 mm	 HM  TC
			

## TİLKİ KUYRUĞU BIÇAKLARI KULLANIM PROGRAMI

	KOD NO	PAKET ADEDİ	TOPLAM UZUNLUK	ÇALIŞMA UZUNLUĞU	YÜKSEKLİK	KALINLIK	DIŞ ARALIĞI	İNÇ BAŞINA DIŞ SAYISI	MALZEME	PASLANMAZ ÇELİK	ÇELİK	SAC	METAL BORU	DEMİR DIŞI YUMUŞAK METALLER	ALUMİNYUM
			mm	mm	mm	mm	mm	TPI							
PASLANMAZ ÇELİK	752043	3	150	128,5	19	0,9	1,8	14	BİM	•	•				
	752044	3	200	178,5	19	0,9	1,8	14	BİM	•	•				
	752045	3	250	228,5	19	0,9	1,8	14	BİM	•	•				
	752035	2	115	93,5	16	1,25	1,4	18	HM/TC	•	○				
METAL	752008	5	150	128,5	16	0,9	1,0	24	BİM		•	○	○		
	752009	5	150	128,5	19	0,9	1,8	14	BİM		•	○	○	○	○
	752012	5	150	128,5	19	0,9	1,0	24	BİM		•	•	○	○	
	752014	5	225	203,5	19	0,9	1,4	18	BİM		•	•	○	○	
	752016	5	150	128,5	19	0,9	1,8	10-14	BİM		•	•	○	•	○
	752015	5	100	78,5	16	0,9	1,8	14	BİM		•			•	○
	752018	5	150	128,5	19	0,9	Kademeli artan dişli	8-10	BİM		•	○	○	•	•
	752017	5	225	203,5	19	0,9	1,8	14	BİM		•	○	•	•	
	752013	5	150	128,5	19	0,9	1,4	18	BİM		•	○	•		
	752021	3	225	203,5	22	1,6	2,5-3,0	8-10	BİM		•		•		
	752019	5	200	178,5	19	1,25	1,8-2,6	10-14	BİM		•	○	•		
	752020	3	150	128,5	22	1,6	2,5-3,0	8-10	BİM		○		•		
AĞŞAP METAL	752022	5	150	128,5	19	0,9	1,8-2,6	10-14	BİM		•	○	•		○
	752023	5	305	283,5	19	0,9	1,8-2,6	10-14	BİM		•		•	○	○
	752024	5	200	178,5	19	1,25	Kademeli artan dişli	6-12	BİM		•				
	752005	200	225	203,5	19	0,9	2,5	10	BİM						
	752028	3	225	203,5	22	1,6	4,3	6	BİM		○				
	752026	5	150	128,5	19	1,25	4,3	6	BİM						
	752027	5	305	283,5	19	1,25	4,3	6	BİM						
	752025	5	150	128,5	19	1,25	4,3	6	BİM						
AĞŞAP	752030	5	150	128,5	19	1,25	4,3	6	HCS						
	752031	5	305	283,5	19	1,25	4,3	6	HCS						
	752033	5	200	178,5	19	1,25	Kademeli artan dişli	6-10	HCS						
	752029	5	225	203,5	19	1,25	8,5	3	HCS						
	752032	5	240	218,5	19	1,5	5,0	5	HCS						
BETON	752040	1	240	193,5	22	1,5	12,7	2	HM/TC						
	752041	1	305	283,5	50	1,5	12,7	2	HM/TC						
	752042	1	455	432,2	50	1,5	12,7	2	HM/TC						
ÖZEL	752034	5	150	128,5	19	1	4,3	6	HAS						
	752039	2	225	203,5	19	1,25	Kum Boyu 30		HM/TC						
	752036	2	150	128,5	19	1,25	4,3	6	HM/TC						
	752037	2	305	283,5	22	1,5	8,5	3	HM/TC						
	752038	2	400	378,5	22	1,5	12,7	2	HM/TC						

























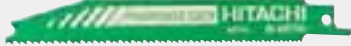











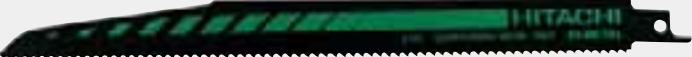

- Bu iş için kullanılabilir
- Kullanılabilir































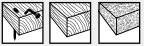







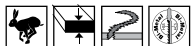





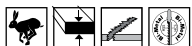





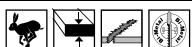











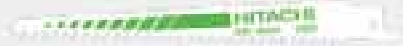















ÇELİK, DÖKÜM BORU	FİBERGLASS MALZEMELER	PVC / PLASTİK MALZEME	PLASTİK BORU, PROFİL	ÇİVİLİ TAHTA	SERT TAHTA	SUNTA	KONTRPLAK	YAŞ TAHTA	KİREÇ TAŞI	POROTON	SANDVIÇ PANEL	KARTONPIYER	YTONG	TUĞLA	KİREMİT	ALÇIPAN	SERAMİK, FAYANS
		o															
		o															
		o															
	•																
o	o																
	o																
o	o	o		o													
o				o													
o				o													
•				o													
	o	o	o	o							o						
o	o	o	o	o							•						
	o	o		•	o	o					•						
				•													
				•	o	o					o						
	o	•		•	o	o					o	o	o				
	o	•	•	•	•	•					o						
	o	•	•	•	•	•					o						
		•	•	•	•	•					o						
		•		•	•	o	o										
		•		•	•	•	o										
		•		•	•	•	o	•									
		•		•	•	•	o	•									
		•		•	•	•	o	•	•	•							
		•		•	•	•	o	•	•	•							
•	o												•			•	o
	•	o									o	•	•	•	o	o	o
	•	•									o	o	•	o	o	o	
	•	•									o	o	•	o	o	o	























PASLANMAZ ÇELİK		KOD NO	PAKET ADEDİ	FIYAT (EUR)
		752043	3	17,27
		150 / 128.5 x 19.0 x 0.9 mm		
		752044	3	20,24
		200.0 / 178.5 x 19.0 x 0.9 mm		
		752045	3	24,79
		250.0 / 228.5 x 19.0 x 0.9 mm		
		752035	2	10,56
		115 / 93.5 x 19 x 1.25 mm		

METAL		KOD NO	PAKET ADEDİ	FIYAT (EUR)
		752008	5	9,73
		150 / 128.5 x 16.0 x 0.9 mm		
		752009	5	9,73
		150.0 / 128.5 x 16.0 x 0.9 mm		
		752012	5	9,64
		150.0 / 128.5 x 19.0 x 0.9 mm		
		752014	5	13,80
		225.0 / 203.5 x 19.0 x 0.9 mm		

METAL		KOD NO	PAKET ADEDİ	FIYAT (EUR)
		<b>752016</b>	5	<b>9,64</b>
		150.0 / 128.5 x 19.0 x 0.9 mm		
				
		<b>752015</b>	5	<b>8,58</b>
		100.0 / 78.5 x 16.0 x 0.9 mm		
				
		<b>752018</b>	5	<b>13,43</b>
		150.0 / 128.5 x 19.0 x 0.9 mm		
				
		<b>752017</b>	5	<b>13,80</b>
		225.0 / 203.5 x 19.0 x 0.9 mm		
				
		<b>752013</b>	5	<b>9,64</b>
		150.0 / 128.5 x 19.0 x 0.9 mm		
				
		<b>752021</b>	3	<b>18,58</b>
		225.0 / 203.5 x 22.0 x 1.6 mm		
				
		<b>752019</b>	5	<b>17,78</b>
		200.0 / 178.5 x 19.0 x 1.25 mm		
				
		<b>752020</b>	3	<b>13,43</b>
		150.0 / 128.5 x 22.0 x 1.6 mm		
				

METAL - AĞAÇ		KOD NO	PAKET ADEDİ	FIYAT (EUR)
		752022	5	9,64
			150.0 / 128.5 x 19.0 x 0.9 mm	
				
		752023	5	16,84
			305.0 / 283.5 x 19.0 x 0.9 mm	
				
		752024	5	16,61
			200.0 / 178.5 x 19.0 x 1.25 mm	
				
		752005	200	424,21
			225.0 / 203.5 x 19.0 x 0.9 mm	
				
		752028	3	18,58
			225.0 / 203.5 x 22.0 x 1.6 mm	
				
		752026	5	15,00
			150.0 / 128.5 x 19.0 x 1.25 mm	
				
		752027	5	21,30
			305.0 / 283.5 x 19.0 x 1.25 mm	
				
		752025	5	13,59
			150.0 / 128.5 x 19.0 x 1.25 mm	
				

 AĞAÇ	KOD NO	PAKET ADEDİ	FİYAT (EUR)
	752030	5	8,58
 		150.0 / 128.5 x 19.0 x 1.25 mm	 
			
	752031	5	16,10
 		305.0 / 283.5 x 19.0 x 1.25 mm	 
			
	752033	3	15,57
 		200.0 / 178.5 x 19.0 x 1.25 mm	 
			
	752029	5	12,44
		225.0 / 203.5 x 19.0 x 1.25 mm	 
			
	752032	5	15,78
		240.0 / 218.5 x 19.0 x 1.5 mm	  
			

 BETON	KOD NO	PAKET ADEDİ	FİYAT (EUR)
	752040	1	20,79
 		240.0 / 193.5 x 22.0 x 1.5 mm	  
			
	752041	1	28,36
 		305.0 / 283.5 x 50.0 x 1.5 mm	  
			
	752042	1	39,56
 		457.0 / 432.2 x 50.0 x 1.5 mm	  
			

ÖZEL	KOD NO	PAKET ADEDİ	FIYAT (EUR)
	752034	5	9,41
	150.0 / 128.5 x 19.0 x 1.0 mm		
	752039	2	15,43
	225.0 / 203.5 x 19.0 x 1.25 mm		
	752036	2	24,36
	150.0 / 128.5 x 19.0 x 1.25 mm		
	752027	2	41,58
	305.0/ 283.5 x 22.0 x 1.5 mm		
	752038	2	46,62
	400.0 / 378.5 x 22.0 x 1.5 mm		

## DAİRE TESTERE BİÇAKLARI



KOD NO	ÇAP (mm)	KESİM GENİŞLİĞİ (mm)	GÖNYE KALINLIĞI (mm)	GÖBEK ÇAPı (mm)	DİŞ SAYISI	UYGULAMA	MAKİNE TİPİ	FİYAT (EUR)
752416	165	2,6	1,6	30/20	18	Ahşap	Daire testere	19,92
752417	165	2,6	1,6	30/20	36	Ahşap	Daire testere	29,58
752418	165	2,6	1,6	30/20	48	Ahşap	Daire testere	33,76
752431	185	2,6	1,6	30	18	Ahşap	Daire testere	20,68
752432	185	2,6	1,6	30	36	Ahşap	Daire testere	30,20
752433	185	2,6	1,6	30	48	Ahşap	Daire testere	34,43
752437	190	2,6	1,6	30	36	Ahşap	Daire testere	32,68
752447	216	2,2	1,6	30	36	Ahşap	Daire testere	30,96
752448	216	2,2	1,6	30	60	Ahşap	Daire testere	35,03
752449	216	2,8	2,2	30	60	Ahşap	Daire testere	42,37
752455	235	2,6	1,6	30	24	Ahşap	Daire testere	26,22
752456	235	2,6	1,6	30	18	Ahşap	Daire testere	23,05
752457	235	2,6	1,6	30	36	Ahşap	Gönye kesme	32,57
752458	235	2,6	1,6	30	60	Ahşap	Gönye kesme	36,59
752459	235	2,4	1,8	30	64	Ahşap	Gönye kesme	53,45
752467	255	2,5	1,8	30	48	Ahşap	Daire testere	42,27
752468	255	2,5	1,8	30	60	Ahşap	Daire testere	45,70
752469	255	2,8	2,2	30	60	Ahşap	Daire testere	52,88
752470	255	2,8	2,2	30	80	Ahşap	Daire testere	58,47
752471	305	2,2	1,8	25,4	60	Çelik	Daire testere	85,03
752473	305	2,2	1,8	25,4	60	Paslanmaz Çelik	Gönye kesme	85,03
752478	335	2,8	1,8	30	60	Ahşap	Gönye kesme	51,93
752479	335	2,5	1,8	30	84	Ahşap	Gönye kesme	77,92
752487	305	2,8	1,8	30	40	Ahşap	Gönye kesme	47,24
752488	305	2,8	1,8	30	60	Ahşap	Gönye kesme	51,93
752489	305	2,8	2,2	30	96	Alüminyum	Gönye kesme	75,16







Not: Diş sayısı 48 ve üzeri olan ve ahşap uygulamalarda kullanılan testere bıçakları, alüminyum için de kullanılabilir.

## ÜÇLÜ PİM + O-RING SETLERİ

KOD NO	Lokma Boyutu	Uzunluk	FİYAT (EUR)
	Ø mm	(mm)	
751474	24	58 - 90	7,43
	27	58 - 90	
	30	60 - 90	
	32	60 - 90	
751475	33	62 - 90	7,66
	34	62 - 90	
	36	62 - 90	
	38	62 - 92	
	41	62 - 92	
	46	64 - 92	



## SV 12SH AKSESUARLARI

	KOD NO	ÖLÇÜ (mm)	TİP	KUM YOĞUNLUK	PAKET ADEDİ	FİYAT (EUR)	
	753401	94	Delta	40	10'luk	3,01	
	753402	94	Delta	60	10'luk	2,94	
	753403	94	Delta	80	10'luk	2,92	
	753404	94	Delta	100	10'luk	2,85	
	753405	94	Delta	120	10'luk	2,83	
	753406	94	Delta	150	10'luk	2,83	
	753407	94	Delta	180	10'luk	2,83	
	753408	94	Delta	240	10'luk	2,83	
	753409	94	Delta	320	10'luk	2,83	
	KOD NO	ÖLÇÜ (mm)	TİP	KUM YOĞUNLUK	PAKET ADEDİ	FİYAT (EUR)	
	753041	114 x 104	Kare	40	10'luk	3,61	
	753042	114 x 104	Kare	60	10'luk	3,52	
	753043	114 x 104	Kare	80	10'luk	3,43	
	753044	114 x 104	Kare	100	10'luk	3,38	
	753045	114 x 104	Kare	120	10'luk	3,36	
	753046	114 x 104	Kare	150	10'luk	3,36	
	753047	114 x 104	Kare	180	10'luk	3,36	
	753048	114 x 104	Kare	240	10'luk	3,36	
753449	114 x 104	Kare	320	10'luk	3,36		
	KOD NO	ÖLÇÜ (mm)	TİP	KUM YOĞUNLUK	PAKET ADEDİ	FİYAT (EUR)	
753450	-	Karma Set	60 - 80 - 120	45'lik	10,79		

## SV 12SG AKSESUARLARI

	KOD NO	ÖLÇÜ (mm)	TİP	KUM BOYU	PAKET ADEDİ	FİYAT (EUR)
	753051	114 x 140	Zımpara Kağıdı	40	10'luk	2,90
	753052	114 x 140	Zımpara Kağıdı	60	10'luk	2,78
	753053	114 x 140	Zımpara Kağıdı	80	10'luk	2,74
	753054	114 x 140	Zımpara Kağıdı	100	10'luk	2,55
	753055	114 x 140	Zımpara Kağıdı	120	10'luk	2,55
	753056	114 x 140	Zımpara Kağıdı	150	10'luk	2,55
	753057	114 x 140	Zımpara Kağıdı	180	10'luk	2,55
	753058	114 x 140	Zımpara Kağıdı	240	10'luk	2,55
	753059	114 x 140	Zımpara Kağıdı	320	10'luk	2,55

## SV 12SD AKSESUARLARI



	KOD NO	ÖLÇÜ (mm)	TİP	KUM BOYU	PAKET ADEDİ	FİYAT (EUR)
	753061	115 x 230	Zımpara Kağıdı	40	10'luk	5,24
	753062	115 x 230	Zımpara Kağıdı	60	10'luk	5,01
	753063	115 x 230	Zımpara Kağıdı	80	10'luk	4,78
	753064	115 x 230	Zımpara Kağıdı	100	10'luk	4,74
	753065	115 x 230	Zımpara Kağıdı	120	10'luk	4,74
	753066	115 x 230	Zımpara Kağıdı	150	10'luk	4,74
	753067	115 x 230	Zımpara Kağıdı	180	10'luk	4,74
	753068	115 x 230	Zımpara Kağıdı	240	10'luk	4,74
	753069	115 x 230	Zımpara Kağıdı	320	10'luk	4,74

## BANT ZIMPARALAR













	KOD NO	ÖLÇÜ (mm)	TİP	KUM BOYU	PAKET ADEDİ	FİYAT (EUR)
	753261	100 x 610	Bant Zımpara	40	5'lik	9,71
	753262	100 x 610	Bant Zımpara	60	5'lik	9,29
	753263	100 x 610	Bant Zımpara	80	5'lik	9,15
	753264	100 x 610	Bant Zımpara	100	5'lik	8,90
	753265	100 x 610	Bant Zımpara	120	5'lik	8,90



## EKSANTRİK ZIMPARA KAĞITLARI

KOD NO	ÇAP (mm)	TİP	KUM BOYU	PAKET ADEDİ	FİYAT (EUR)	
<b>KIRMIZI seri</b> • ahşap çeşitleri, sunta, metal						
	753101	Ø 125	Yuvarlak	40	10'luk	3,98
	753102	Ø 125	Yuvarlak	60	10'luk	3,86
	753103	Ø 125	Yuvarlak	80	10'luk	3,63
	753104	Ø 125	Yuvarlak	100	10'luk	3,59
	753105	Ø 125	Yuvarlak	120	10'luk	3,59
	753106	Ø 125	Yuvarlak	150	10'luk	3,59
	753107	Ø 125	Yuvarlak	180	10'luk	3,59
	753108	Ø 125	Yuvarlak	240	10'luk	3,59
	753109	Ø 125	Yuvarlak	320	10'luk	3,59
	753110	Ø 125	Yuvarlak	400	10'luk	3,59
<b>BEYAZ seri</b> • boya, lake, cila, otomotiv, gemi endüstri						
	753111	Ø 150	Yuvarlak	40	10'luk	4,81
	753112	Ø 150	Yuvarlak	60	10'luk	4,62
	753113	Ø 150	Yuvarlak	80	10'luk	4,35
	753114	Ø 150	Yuvarlak	100	10'luk	4,30
	753115	Ø 150	Yuvarlak	120	10'luk	4,30
	753116	Ø 150	Yuvarlak	150	10'luk	4,30
	753117	Ø 150	Yuvarlak	180	10'luk	4,30
	753118	Ø 150	Yuvarlak	240	10'luk	4,30
	753119	Ø 150	Yuvarlak	320	10'luk	4,30
	753151	Ø 150	Yuvarlak	60	100'lük	40,80
	753152	Ø 150	Yuvarlak	80	100'lük	40,80
	753153	Ø 150	Yuvarlak	100	100'lük	40,71
	753154	Ø 150	Yuvarlak	120	100'lük	40,71
	753155	Ø 150	Yuvarlak	150	100'lük	40,71
	753156	Ø 150	Yuvarlak	180	100'lük	40,71
	753157	Ø 150	Yuvarlak	220	100'lük	40,71
	753158	Ø 150	Yuvarlak	240	100'lük	40,71
	753159	Ø 150	Yuvarlak	280	100'lük	40,71
	753160	Ø 150	Yuvarlak	320	100'lük	40,71
	753161	Ø 150	Yuvarlak	400	100'lük	40,71

## MATKAP MANDRENLERİ



KOD NO	GİRİŞ MİLİ	KAPASİTE	ÖZELLİK	FİYAT (EUR)	
	752082	1/4"	1 - 10 mm	Anahtarlı	19,07
	752072	3/8"	1,5 - 10 mm	Anahtarlı	10,60
	752078	3/8"	1,5 - 10 mm	Anahtarsız	19,76
	752079	3/8"	1,5 - 10 mm	Anahtarsız	20,79
	752057	1/2"	1 - 10 mm	Anahtarlı	10,60
	A100036	1/2"	1,5 - 13 mm	Anahtarlı	13,89
	752056	1/2"	1,5 - 13 mm	Anahtarlı	15,82
	752058	1/2"	1,5 - 13 mm	Anahtarlı	15,82
	752062	1/2"	1 - 10 mm	Anahtarsız	19,76
	752063	1/2"	1,5 - 13 mm	Anahtarsız	25,51
	752064	1/2"	1,5 - 13 mm	Anahtarsız / Kilitli	26,59
	950284	5/8"	3 - 16 mm	Anahtarlı	113,34
	752097	SDS-Plus Adaptörlü	1.5 - 13 mm	Anahtarlı	24,66

## BATARYALAR



	KOD NO	MODEL	AKÜ TİPİ	VERSİYON	VOLTAJ (Volt)	AKÜ KAPASİTESİ (Ah)	FİYAT (EUR)	
	326299	EBM 315	Li-ion	Kaset Tip	3,6	1,5	29,49	
	333431 (309365)*	BCC715	Ni-Cd	Kaset Tip	7,2	1,5	33,88	
	329371	BCL 1015	Li-ion	Kaset Tip	10,8	1,5	70,79	
	333292	BCL 1030	Li-ion	Kaset Tip	10,8	3,0	112,65	
	333156 (320608-322629)*	BCC1215 (EB1214S)*	Ni-Cd	Kaset Tip	12	1,5	62,63	
	320387	EB1220BL	Ni-Cd	Kaset Tip	12	2,0	96,46	
	326053	EB1233X	Ni-MH	Kaset Tip	12	3,3	130,48	
  	333159 (319933-322633)*	BCC1415 (EB1414S)*	Ni-Cd	Kaset Tip	14,4	1,5	80,50	
	315130	EB14B	Ni-Cd	Kaset Tip	14,4	2,0	111,16	
	330558 (329877)*	BSL1415X (BSL1415)*	Li-ion	Slide Tip	14,4	1,5	100,28	
	327729	BCL1415	Li-ion	Kaset Tip	14,4	1,5	84,09	
	335784	BSL1425	Li-ion	Slide Tip	14,4	2,5	109,11	
	326824 (326236)*	BCL1430	Li-ion	Kaset Tip	14,4	3,0	126,80	
	329083	BSL1430	Li-ion	Slide Tip	14,4	3,0	126,80	
	335786	BSL1450	Li-ion	Slide Tip	14,4	5,0	150,40	
	  	333161 (322882)*	BCC1815 (EB1814S)*	Ni-Cd	Kaset Tip	18	1,5	99,34
		327731	BCL1815	Li-ion	Kaset Tip	18	1,5	109,11
330557		BSL1815X	Li-ion	Slide Tip	18	1,5	129,74	
335788		BSL1825	Li-ion	Slide Tip	18	2,5	141,54	
326240		EBM1830	Li-ion	Kaset Tip	18	3,0	154,84	
330068		BSL1830	Li-ion	Slide Tip	18	3,0	154,84	
335790		BSL1850	Li-ion	Slide Tip	18	5,0	187,27	
	326555	EB2420	Ni-Cd	Slide Tip	24	2,0	221,97	
	328033	BSL2530	Li-ion	Slide Tip	25	3,0	221,17	
	328036	BSL3626	Li-ion	Slide Tip	36	2,6	309,63	

(\* Parantez içinde belirtilen kodlar aynı teknik özelliklere sahip eski kodlardır.)

## ŞARJ MAKİNELERİ

	KOD NO	MODEL	VOLTAJ (Volt)	ŞARJ TİPİ	VERSİYON	ŞARJ SÜRESİ (Dakika)	FİYAT (EUR)
 	UC3SFL	UC 3SFL	3,6	Li-ion	Kaset Tip	30	69,00
	UC10SL2	UC 10SL2	10,8	Li-ion	Kaset Tip	40	66,70
	UC18YGL2	UC 18YGL2	7,2 / 9,6 / 12 / 14,4 / 18	Li-ion / Ni-Cd / Ni-MH	Kaset Tip	35-90	54,05
	UC18YFSL	UC 18YFSL	14,4 - 18	Li-ion	Slide Tip	60	82,87
	UC36YSL	UC 36YSL	14,4 - 36	Li-ion	Slide Tip	60	110,40

## AKÜLÜ FENERLER

	KOD NO	MODEL	AÇIKLAMA	VOLTAJ (Volt)	FİYAT (EUR)
 	UB12D	UB12D	<ul style="list-style-type: none"> <li>• 9B6 V - 12 V Hitachi akü ile çalışır</li> <li>• 110° eksenli etrafında dönebilen kafa</li> <li>• Akü ve şarj cihazı fiyata dahil değildir</li> </ul>	9,6 - 12	19,83
	UB12DL	UB12DL	<ul style="list-style-type: none"> <li>• Kuvvetli floresan aydınlatma</li> <li>• 3.0 Ah'lik bir dolu akü ile yaklaşık 3.6 saat floresan, 150 saat LED (pilot ışık) aydınlatma</li> <li>• Çok amaçlı kullanım</li> <li>• 9.6 V - 12 V Hitachi akü ile çalışır</li> <li>• Akü ve şarj cihazı fiyata dahil değildir</li> </ul>	9,6 - 12	25,78
	UB18D	UB18D	<ul style="list-style-type: none"> <li>• 14.4 V - 18 V Hitachi akü ile çalışır</li> <li>• 110° eksenli etrafında dönebilen kafa</li> <li>• Akü ve şarj cihazı fiyata dahil değildir</li> </ul>	14,4 - 18	21,81
	UB18DL	UB18DL	<ul style="list-style-type: none"> <li>• 14.4 V - 18 V Hitachi Lityum-iyon, Ni-Cd ve Ni-MH akü ile çalışır</li> <li>• Kuvvetli floresan aydınlatma</li> <li>• Çok amaçlı kullanım</li> <li>• Akü ve şarj cihazı fiyata dahil değildir</li> </ul>	14,4 - 18	27,76







# HITACHI



## **KALE**!!!®

**Gücün Kalesi, Kale'nin Gücü!**

### **Kale Hırdavat ve Makina A.Ş.**

Defterdar Mahallesi, Savaklar Caddesi, No:15

34050 Edirnekapı-Eyüp/İstanbul

Telefon : +90 (0)212 533 52 55

Faks : +90 (0)212 533 10 05

E-posta : info@kalemakina.com

[www.kalemakina.com](http://www.kalemakina.com)